

This drawing is provided to customers free of charge and the details shown are subject to the accuracy of the information provided to British Gypsum at the time the drawing was originally requested. No duty of care is owed to the recipient or any other third party and British Gypsum cannot accept liability in respect of the details shown. The drawing should therefore be approved by the project design and management authority before use to ensure that it meets with their specific project requirements. It should also be read in conjunction with British Gypsum's current literature available at www.british-gypsum.com. Taping and finishing in accordance with British Gypsum's current recommendations is assumed (with the exception of FireCase system). Please note the drawing may show British Gypsum products fixed by or to products that are non-British Gypsum products/fixings please refer to Specifying Authority for specification details. This drawing is valid at the time of issue, please check with British Gypsum for the latest version.

FireCase

- 1 Indicative steel column
- 2 2 layers Glasroc F FireCase fixed together with Glasroc F FireCase Screws at 150mm centres. Board joints staggered by minimum 600mm between adjacent sides & layers
- 3 Gypframe stud bonded to Glasroc F FireCase with continuous bead of Gyproc Sealant (2 beads for 92mm & 146mm studs) & fixed with suitable British Gypsum screws at 600mm centres (in 2 lines staggered by 300mm for 92mm & 146mm studs). Allow 24 hours before boarding partition
- 4 Gypframe stud suitably fixed through Glasroc F FireCase to column at 600mm centres (in 2 lines for 92mm & 146mm studs)
- 5 Suitable size Z section by others fixed between column flanges at 600mm centres
- 6 Gypframe stud suitably fixed through Glasroc F FireCase to Z sections at 600mm centres (in 2 lines for 92mm & 146mm studs)

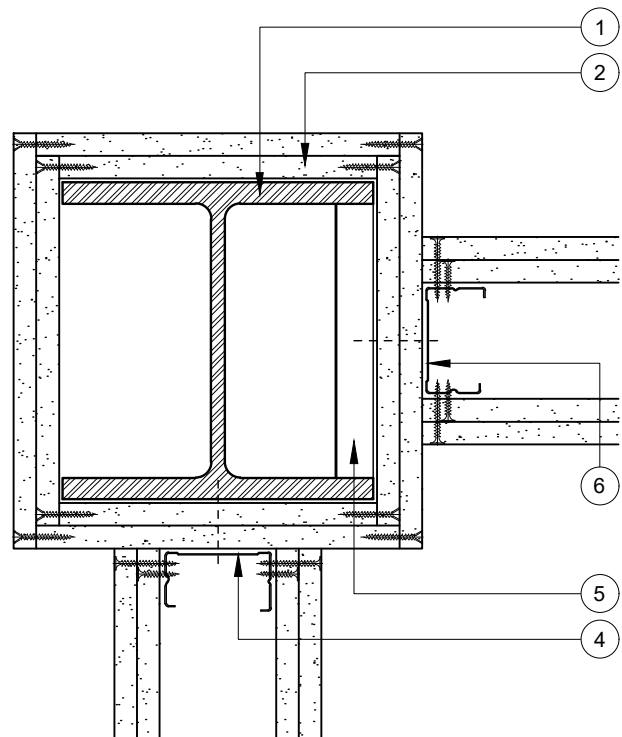
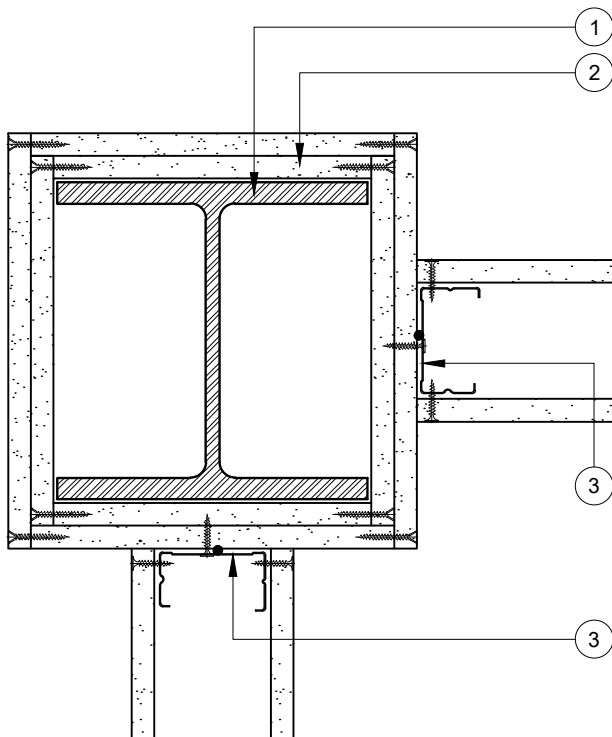

ⓘ Important Information

Fire resistance BS 476: Part 22: 1987

- Up to 60 minutes through partition subject to specification

ⓘ Important Information

Fire resistance BS 476: Part 22: 1987

- Up to 120 minutes through partition subject to specification

Column & Partition Junction

Maximum 600mm Column Width

Partition to BS 5234 Light & Medium Duty

No Special Requirements for Pressure

Column & Partition Junction

Maximum 600mm Column Width

Partition to BS 5234 Heavy & Severe Duty



Technical Support Team
Tel: 0115 945 6123
british-gypsum.com

Title:

FireCase

Steel Angles and 2 Layers Board

Typical Details Read with Project Specification

Scale at A4:	Date:	Drawn:	Approved:	Dwg No.:	Rev.:
1:5	Jan 20	MRC	MBH	TY-771-ANL2-02	