

# Standard Detail

This drawing provides general guidance where no performance criteria is given and site specific conditions are not taken into account

## GypLyner Encase

- 1 Indicative steel column or beam
- 2 Two layers Gyproc plasterboard or Glasroc specialist board fixed with suitable British Gypsum screws at 300mm centres
- 3 Gypframe GL1 Lining Channel clipped over steel framing clips. Lining channels extended with Gypframe GL3 Channel Connector (not shown)
- 4 Gypframe GL10 Steel Framing Clips friction fitted to flanges at 800mm centres and 100mm from each end of encasement
- 5 Gypframe GFS1 Fixing Strap to support outer layer board joints. Board joints staggered by 600mm between adjacent sides. Where column/beam width exceeds 600mm noggings of Gypframe GL1 Lining Channel required at 600mm centres
- 6 Gypframe GA2 Steel Angle suitably fixed to steel column/beam at 600mm centres
- 7 Gypframe GL1 Lining Channel noggings at 600mm centres (300mm centres for 92mm and 146mm studs in adjacent partition) with ends tabbed and fixed to lining channels with suitable British Gypsum wafer head screws
- 8 Gypframe stud fixed through board to noggings with suitable British Gypsum screws at 600mm centres (in two lines staggered by 300mm for 92mm and 146mm studs)
- 9 Gypframe channel fixed through board to noggings with suitable British Gypsum screws at 600mm centres (in two lines staggered by 300mm for 94mm and 148mm channels)

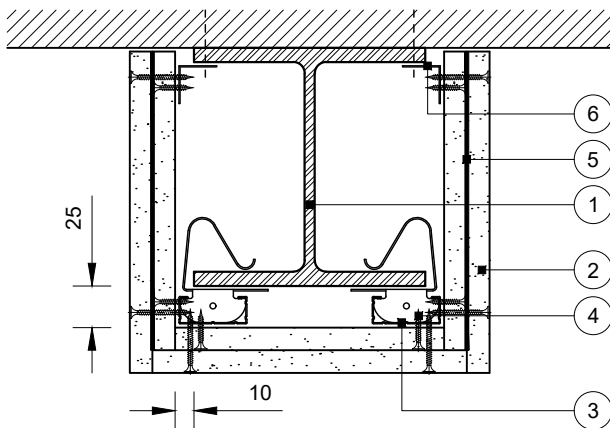

Three sided column/beam encasement

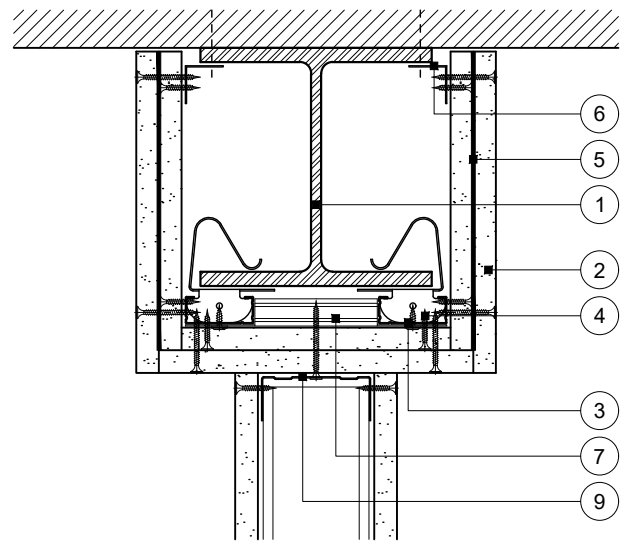

Beam and partition junction

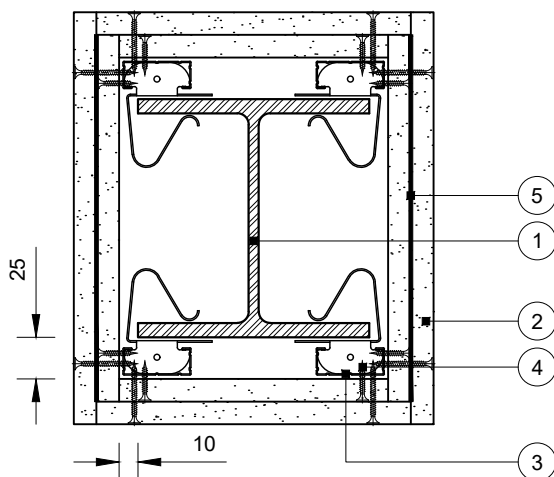

Four sided column/beam encasement

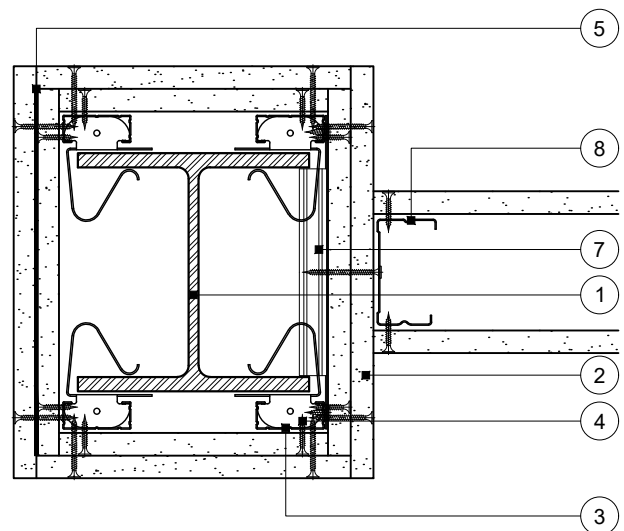

Column and partition junction

**Title:** GypLyner Encase  
Two layers board  
Standard details read with project specification

**Scale at A4:** 1:5  
**Date:** October 2021  
**Dwg No.:** ST-422-CLL2-01

**Drawn:** MRC  
**Approved:** MBH  
**Revision:**

Technical Support Team | british-gypsum.com

This drawing is provided to customers free of charge and the details shown are subject to the accuracy of the information provided to British Gypsum at the time the drawing was originally requested. The drawing should therefore be approved by the project design and management authority before use to ensure that it meets with their specific project requirements. It should also be read in conjunction with British Gypsum's current literature available at [www.british-gypsum.com](http://www.british-gypsum.com). Taping and finishing in accordance with British Gypsum's current recommendations is assumed (with the exception of FireCase system). Please note the drawing may show British Gypsum products fixed by or to products that are non-British Gypsum products/fixings please refer to Specifying Authority for specification details. This drawing is valid at the time of issue, please check with British Gypsum for the latest version. No duty of care is owed to the recipient or any third party and British Gypsum excludes all liability in respect of the details shown save where death or personal injury is caused due to British Gypsum's negligence or for fraud.