

The Building Test Centre

Fire Acoustics Structures

The Building Test Centre
East Leake
Loughborough
Leics, LE12 6NP
Tel: (0115) 945 1564
Email: btc.testing@saint-gobain.com

Report Number **BTC 22834A**

An acoustic test report covering laboratory sound insulation testing to BS EN ISO 10140-2:2021 on a timber stud partition using 63 mm x 38 mm timber studs clad with a single layer of 15 mm thick Gyproc SoundBloc 15mm each side.

Test date: 20th July 2023

Report issued date: 20th July 2023

www.btconline.co.uk

Customer: **British Gypsum**
East Leake
Loughborough
Leicestershire
LE12 6HX

Customer: **British Gypsum**

BTC 22834A: Page 1 of 13



0296

The Building Test Centre

Fire Acoustics Structures

The Building Test Centre
East Leake
Loughborough
Leics, LE12 6NP
Tel: (0115) 945 1564
Email: btc.testing@saint-gobain.com

TABLE OF CONTENTS

FOREWORD	3
REPORT AUTHORISATION	3
TEST REPORT AMENDMENTS	4
TEST CONSTRUCTION	5
TEST MATERIALS	7
<i>Plasterboard</i>	7
<i>Timber Components</i>	7
<i>Fasteners</i>	7
<i>Miscellaneous Components</i>	7
TEST RESULTS	9
TEST PROCEDURE	9
LIMITATIONS	9
APPENDIX A - TEST DATA	10
APPENDIX B - TEST METHOD AND CONDITIONS	12

Customer: **British Gypsum**

BTC 22834A: Page 2 of 13



0296

The Building Test Centre

Fire Acoustics Structures

The Building Test Centre
East Leake
Loughborough
Leics, LE12 6NP
Tel: (0115) 945 1564
Email: btc.testing@saint-gobain.com

FOREWORD

The test sponsor was British Gypsum.

The test specimen was installed by Daniel Jones and Matt Skeen between the 19th and 20th July 2023.

The Building Test Centre played no role in the design or selection of the materials comprising the test specimen. This information is provided by British Gypsum.

REPORT AUTHORISATION

Report Author



Matthew Harrison
BEng (Hons) MSc
Scientist

Authorised by



James Stonell
MIOA
Senior Scientist

The Building Test Centre will not discuss the content of this report without written permission from the test sponsor. The Building Test Centre retains ownership of the test report content but authorises the test sponsor to reproduce the report as necessary in its entirety only.

Customer: **British Gypsum**

BTC 22834A: Page 3 of 13



0296

TEST CONSTRUCTION

The test specimen was constructed in an aperture having an overall opening of 2400 mm (high) x 3600 mm (wide).

63 mm x 38 mm timber head and base plates were screw fixed at 600 mm centres to the head and base of the test aperture using 65 mm long British Gypsum Drywall Screws 65mm.

63 mm x 38 mm timber studs were positioned between the head and base plates at each end of the aperture and fixed using 65 mm long British Gypsum Drywall Screws 65mm spaced at 600 mm centres.

63 mm x 38 mm timber studs were positioned at 600 mm centres between the head and base plates and skew fixed using 65 mm long British Gypsum Drywall Screws 65mm.

The framework was clad with a single layer of 15 mm thick Gyproc SoundBloc 15mm each side.

The boards were screw fixed around the perimeter of the board and the intermediate stud positions at 300 mm centres using 40 mm long British Gypsum Collated Drywall Screws 40mm.

All vertical joints were staggered between layers. All joints and screw heads were taped and the perimeter was taped and sealed with Gyproc Sealant.

The Building Test Centre

Fire Acoustics Structures

The Building Test Centre
East Leake
Loughborough
Leics, LE12 6NP
Tel: (0115) 945 1564
Email: btc.testing@saint-gobain.com

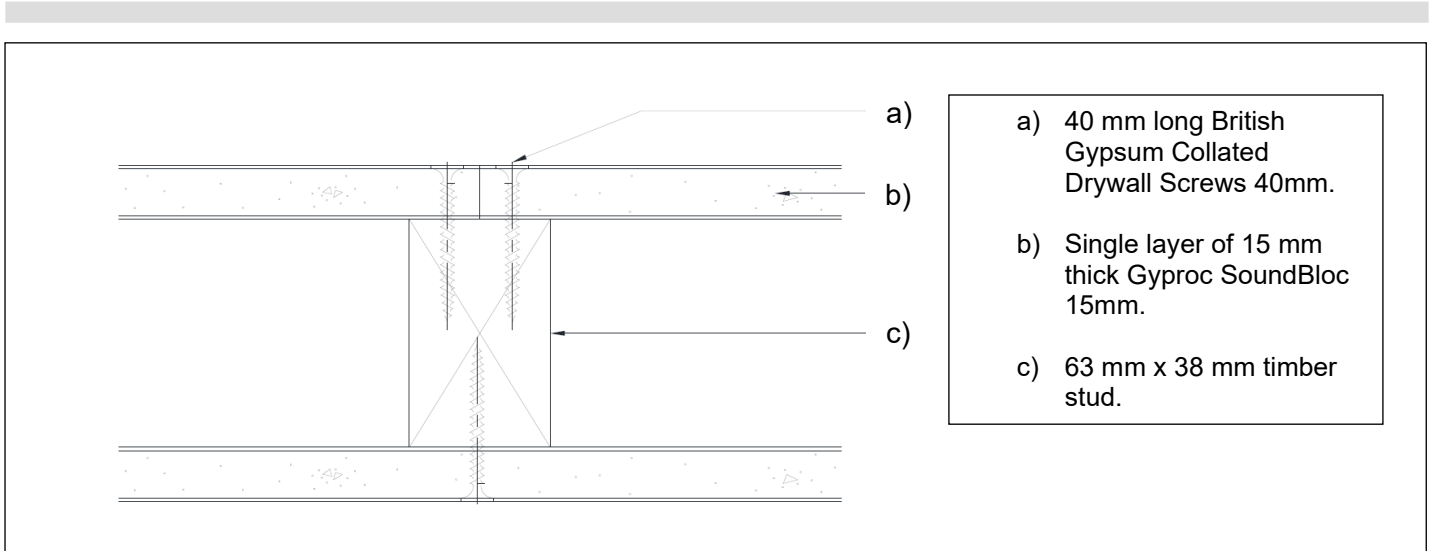

Figure 1. Horizontal cross section view

The descriptions of individual components making up the test specimen were provided by the customer and were checked for accuracy wherever possible.

TEST MATERIALS

Plasterboard

- i) Nominally 2400 mm (long) x 1200 mm (wide) x 15 mm (thick) Gyproc SoundBloc 15mm manufactured by British Gypsum, ex Sherburn.

Surface density:	14.8 kg/m ²
Average thickness:	14.9 mm
Board Code:	31 137 23 16:43
	31 137 23 16:42
	31 137 23 16:42

The surface densities were calculated using the actual weight and size of a selection of the boards used in the test specimen.

Material dimensions were supplied by the customer.

Timber Components

- i) 63 mm x 38 mm timber studs.
ii) 63 mm x 38 mm timber head and base plates.

All timber components are supplied by the customer.

Fasteners

- i) 65 mm long British Gypsum Drywall Screws 65mm.
ii) 40 mm long British Gypsum Collated Drywall Screws 40mm.

All fasteners supplied by The Building Test Centre.

Miscellaneous Components

- i) Gyproc Sealant supplied by The Building Test Centre.
ii) Joint tape supplied by The Building Test Centre.

Where measurements could not be taken and were provided by the customer or the manufacturer e.g. from material labelling, or where mass and dimension measurements were provided by the customer or the manufacturer e.g. customer has completed material dimension forms the results only apply to the sample as received.

Customer: **British Gypsum**

BTC 22834A: Page 7 of 13



0296

The Building Test Centre

Fire Acoustics Structures

The Building Test Centre
East Leake
Loughborough
Leics, LE12 6NP
Tel: (0115) 945 1564
Email: btc.testing@saint-gobain.com

All data and materials supplied by the customer or manufacturer are clearly identified.

Material information was sampled and recorded according to procedure AP070 vs. 1.2.

Customer: **British Gypsum**

BTC 22834A: Page 8 of 13



0296

TEST RESULTS

Test Code	Description	Weighted Airborne Sound Reduction Index R_w (C; Ctr)
H22834AA	Single layer of 15 mm thick Gyproc SoundBloc 15mm each side on 63 mm x 38 mm timber studs.	40 (-2;-7) dB

For full data see Appendix A of this report.

Test conducted in accordance with BS EN ISO 10140-2:2021 except for Clause A.2 in BS EN ISO 10140-4:2021 where minimum distances for measurements at frequencies under 100Hz cannot be met.

Rated in accordance with BS EN ISO 717-1: 2020.

No visible damage of the test specimen occurred during test.

Testing to BS EN ISO 10140-2:2021 conforms to the requirements of BS EN ISO 140-3:1995 (withdrawn).

Where the uncertainty of measured values is stated, (e.g. temperature, relative humidity and static pressure) the reported expanded uncertainty is based on a standard uncertainty multiplied by a coverage factor $k=2$, providing a coverage probability of approximately 95%. The uncertainty evaluation has been carried out in accordance with UKAS requirements.

TEST PROCEDURE

The test specimen (3.6 m x 2.4 m) was constructed in a wall dividing two reverberant rooms of approximately 98 m³ and 62 m³. The accuracy of the test method conforms to BS EN 20140-2:1993, the test procedure used is detailed in the test data in Appendix A of this report. Broad-band white noise was used to measure the level differences and broad-band pink noise was used to measure the reverberation times. Third octave band pass filters were used in real time mode. See appendix B for further information.

LIMITATIONS

The results only relate to the behaviour of the element of construction under the particular conditions of test; they are not intended to be the sole criteria for assessing the potential acoustic performance of the element in use nor do they reflect the actual behaviour.

Customer: **British Gypsum**

BTC 22834A: Page 9 of 13



0296

APPENDIX A - TEST DATA

Test Code: H22834AA
Test Date: 20/07/2023

Freq. Hz	R dB
50	24.9
63	19.3
80	12.0
100	16.0
125	21.8
160	27.7
200	33.8
250	34.3
315	32.4
400	35.8
500	39.4
630	39.3
800	42.7
1 000	44.7
1 250	47.5
1 600	48.5
2 000	45.4
2 500	37.6
3 150	37.9
4 000	43.2
5 000	49.0

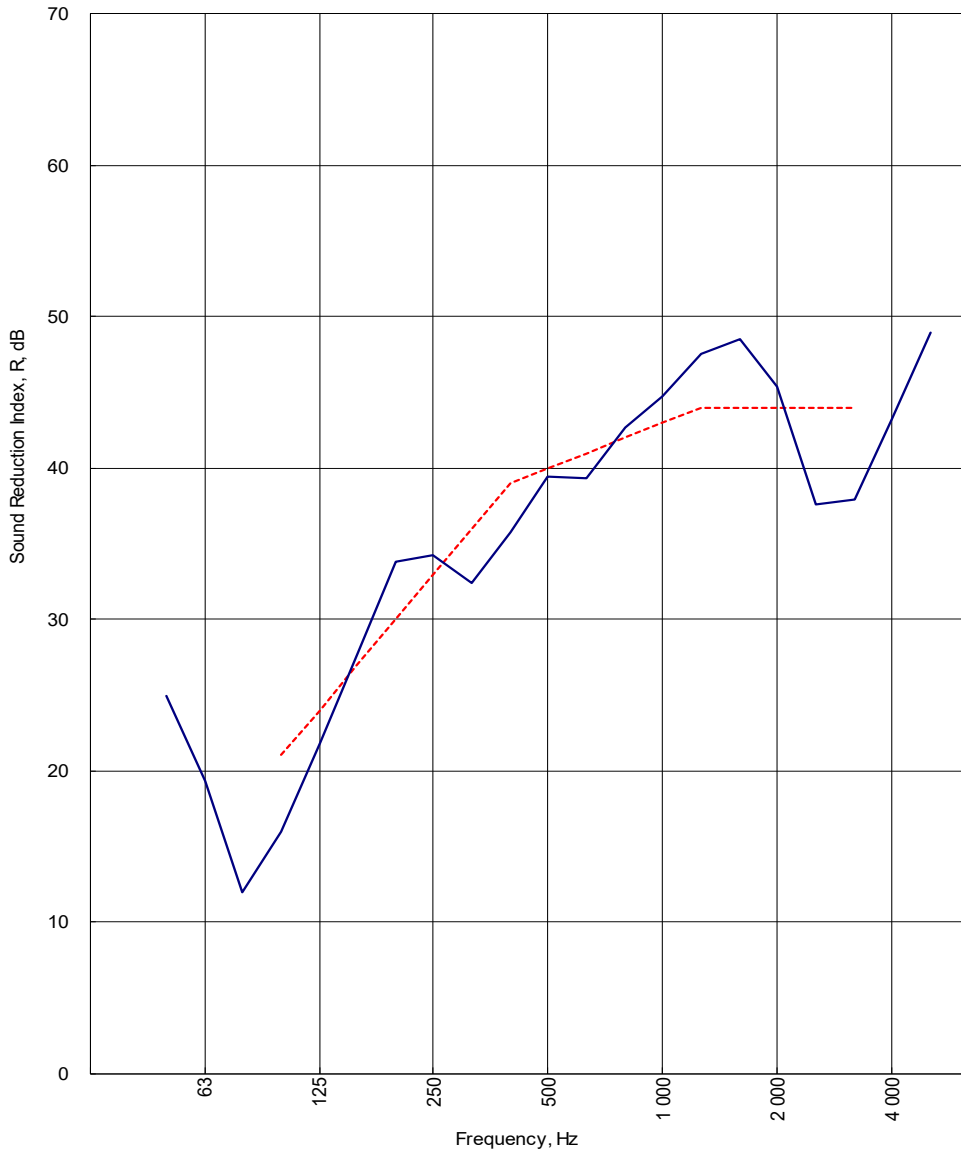

--- Curve of reference values (ISO 717-1)

Rating according to BS EN ISO 717-1:2020	R_w (C;C_{tr}) = 40 (-2;-7) dB		
	Max dev. 6.4 dB at 2 500 Hz		
Evaluation based on laboratory measurement results obtained by an engineering method (T20) :	C ₅₀₋₃₁₅₀ = -3 dB	C ₅₀₋₅₀₀₀ = -2 dB	C ₁₀₀₋₅₀₀₀ = -1 dB
	C _{tr,50-3150} = -10 dB	C _{tr,50-5000} = -10 dB	C _{tr,100-5000} = -7 dB

Customer: **British Gypsum**

BTC 22834A: Page 10 of 13



0296

LABORATORY AIRBORNE SOUND INSULATION TEST - BS EN ISO 10140-2:2021

Test Code: **H22834AA**

Test Date: **20/07/2023**

Specimen Area, S = **8.64** m²

	Room T2	Room T1	
Room Volume, m ³ :	98	60.2	
Temperature, deg.C:	20.4	20.4	± 0.3
Rel. Humidity, %RH:	61.3	60.8	± 1.6
Static Pressure, Pa:	101000	101000	± 65

Freq Hz	Test Room T2 to Test Room T1						R dB	U.Dev. dB	R 1/1Oct dB
	Source dB	Rec. (uc) dB	Bgrnd dB	Rec. (corr) dB	Rev.time Sec	Corr. dB			
50	66.2	39.2	19.3	39.2	0.68	-2.1	24.9		
63	69.1	49.3	9.4	49.3	0.99	-0.5	19.3		15.8
80	75.6	61.6	7.7	61.6	0.70	-2.0	12.0		
100	81.9	65.5	7.9	65.5	1.01	-0.4	16.0	5.0	
125	85.2	63.8	5.2	63.8	1.22	0.4	21.8	2.2	19.5
160	85.4	58.8	5.3	58.8	1.44	1.1	27.7		
200	88.9	57.1	15.7	57.1	1.75	2.0	33.8		
250	90.1	57.7	6.6	57.7	1.74	1.9	34.3		33.4
315	92.9	62.7	19.9	62.7	1.85	2.2	32.4	3.6	
400	93.6	60.2	9.7	60.2	1.95	2.4	35.8	3.2	
500	93.4	56.5	8.8	56.5	1.99	2.5	39.4	0.6	37.8
630	92.5	55.5	9.8	55.5	1.89	2.3	39.3	1.7	
800	93.1	52.4	12.2	52.4	1.75	2.0	42.7		
1 000	93.2	50.6	15.6	50.6	1.79	2.1	44.7		44.5
1 250	93.7	48.3	5.6	48.3	1.80	2.1	47.5		
1 600	96.4	49.9	5.5	49.9	1.78	2.0	48.5		
2 000	98.1	54.6	6.3	54.6	1.72	1.9	45.4		41.4
2 500	96.6	60.3	5.7	60.3	1.49	1.3	37.6	6.4	
3 150	95.0	58.1	6.3	58.1	1.40	1.0	37.9	6.1	
4 000	92.3	50.2	7.5	50.2	1.42	1.1	43.2		41.3
5 000	89.6	41.5	8.8	41.5	1.36	0.9	49.0		
6 300									
8 000									
10 000									

Single Figure Ratings	Rw	C	Ctr	Total U. Dev., dB	28.8
BS EN ISO 717-1: 2020	dB	dB	dB		
	40	-2	-7		
	(100-5000)	-1	-7		
	(50-3150)	-3	-10		
	(50-5000)	-2	-10		
				Procedure: AP 688 vs 1.0	
				Worksheet: 140_3_1W850.XLS	

Customer: **British Gypsum**

BTC 22834A: Page 11 of 13



0296

APPENDIX B - TEST METHOD AND CONDITIONS

Method

The average sound pressure level in each 1/3 octave band is measured using a rotating microphone boom, positioned such that the minimum distance between microphone and sound source is 1 m and between microphone and room boundaries is 0.7 m. The rotating microphone has a sweep radius of at least 1 m and is inclined in relation to the boundaries at an angle of at least 30 ° to the horizontal. The microphone has a traverse time of 32 seconds, and the sound pressure levels are averaged over 64 seconds which is equivalent to two complete sweeps of the microphone boom.

The equivalent absorption area of the receiving room is determined by producing the arithmetic average of twelve reverberation times and applying this to the Sabine formula.

Test Chamber Layout

The test suite is constructed to be as independent from the surround building as is physically possible in order to minimise flanking transmission paths.

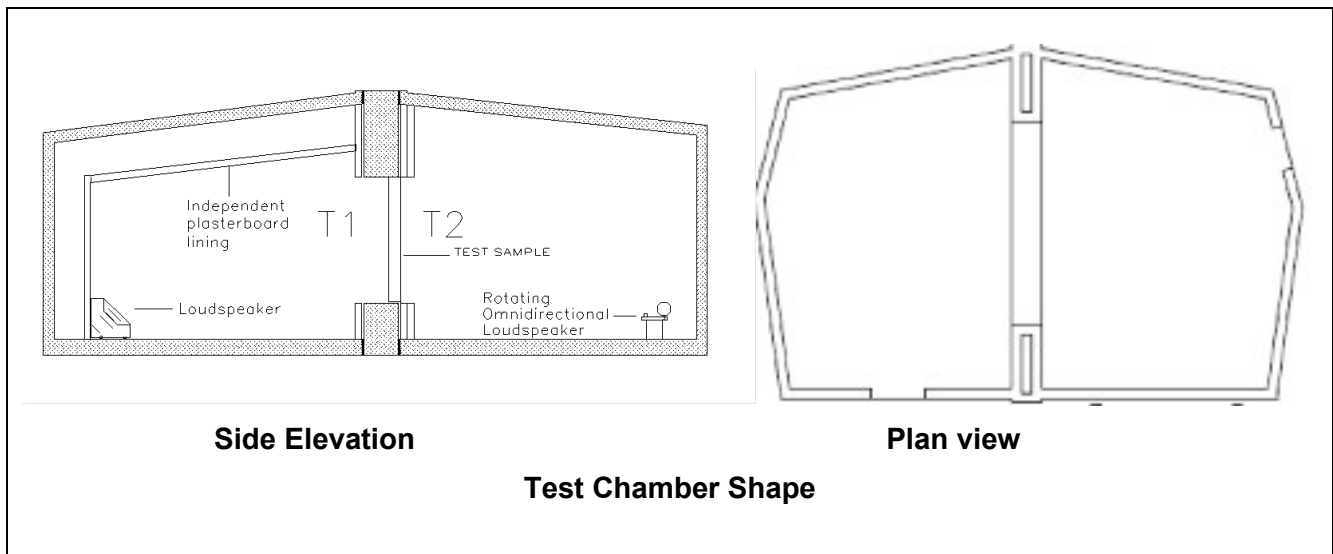

The source room (T2) contains two perspex diffusers of approximately 900 mm x 1220 mm. Panel absorbers are used to ensure reverberation times in source room (T2) are between one and two seconds at all frequencies at and above 100 Hz. An omni-directional loudspeaker sound source is placed near a back corner of the source room (T2), rotating at 1 rpm and at least 0.7 m from any room boundary. A stationary loudspeaker sound source is placed in the corner of the receiving room (T1) opposite the test specimen.

Mounting

The BTC has a solid concrete frame which has been additionally lined to give improved reduction of flanking transmission. This is in order to ensure that, as far as possible, lab limits will not restrict the real performance measurement of just the test specimen.

Recommendations for installation position within the niche are given in our Installation Guidance Document. Details of actual installation position are held by the BTC in the Test Report folder.

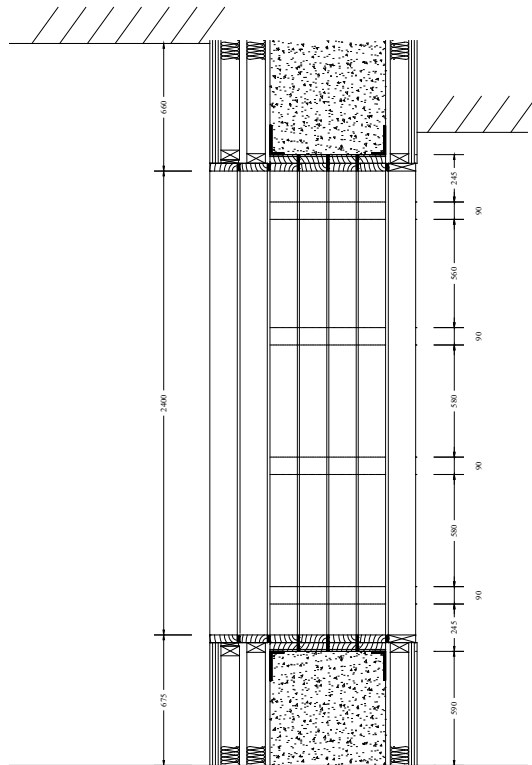

Cross section of test aperture

Lab Limits

The laboratory limit for measurement due to flanking is (combined BTC 11709A, BTC13562EA, BTC 15829A and BTC 19792A).

Freq Hz	50	63	80	100	125	160	200	250	315	400	500	630	800	1000	1250	1600	2000	2500	3150	4000	5000
R _w max	45.0	46.9	58.5	62.4	62.9	67.7	71.2	77.2	84.2	92.0	97.7	101.5	103.8	97.6	102.4	104.8	101.8	102.9	98.7	96.4	96.3

Uncertainties for test

The uncertainties values for test are taken from ISO 12999-1 situation B situ standard deviation.

Freq Hz	50	63	80	100	125	160	200	250	315	400	500	630	800	1000	1250	1600	2000	2500	3150	4000	5000
Standard Uncertainty	4.0	3.6	3.2	2.8	2.4	2.0	1.8	1.6	1.4	1.2	1.1	1.0	1.0	1.0	1.0	1.0	1.0	1.3	1.6	1.9	2.2

Descriptor	R _w	R _w + C (100-3150)	R _w + C _{tr} (100-3150)	R _w + C (100-5000)	R _w + C _{tr} (100-5000)	R _w + C (50-3150)	R _w + C _{tr} (50-3150)	R _w + C (50-5000)	R _w + C _{tr} (50-5000)
Standard Uncertainty	0.9	0.9	1.1	1.1	1.1	1.0	1.3	1.1	1.0

Customer: **British Gypsum**

BTC 22834A: Page 13 of 13



0296