

# Construction Detail

This drawing provides guidance to achieve indicative performance criteria for specific design conditions

## GypWall Shaft

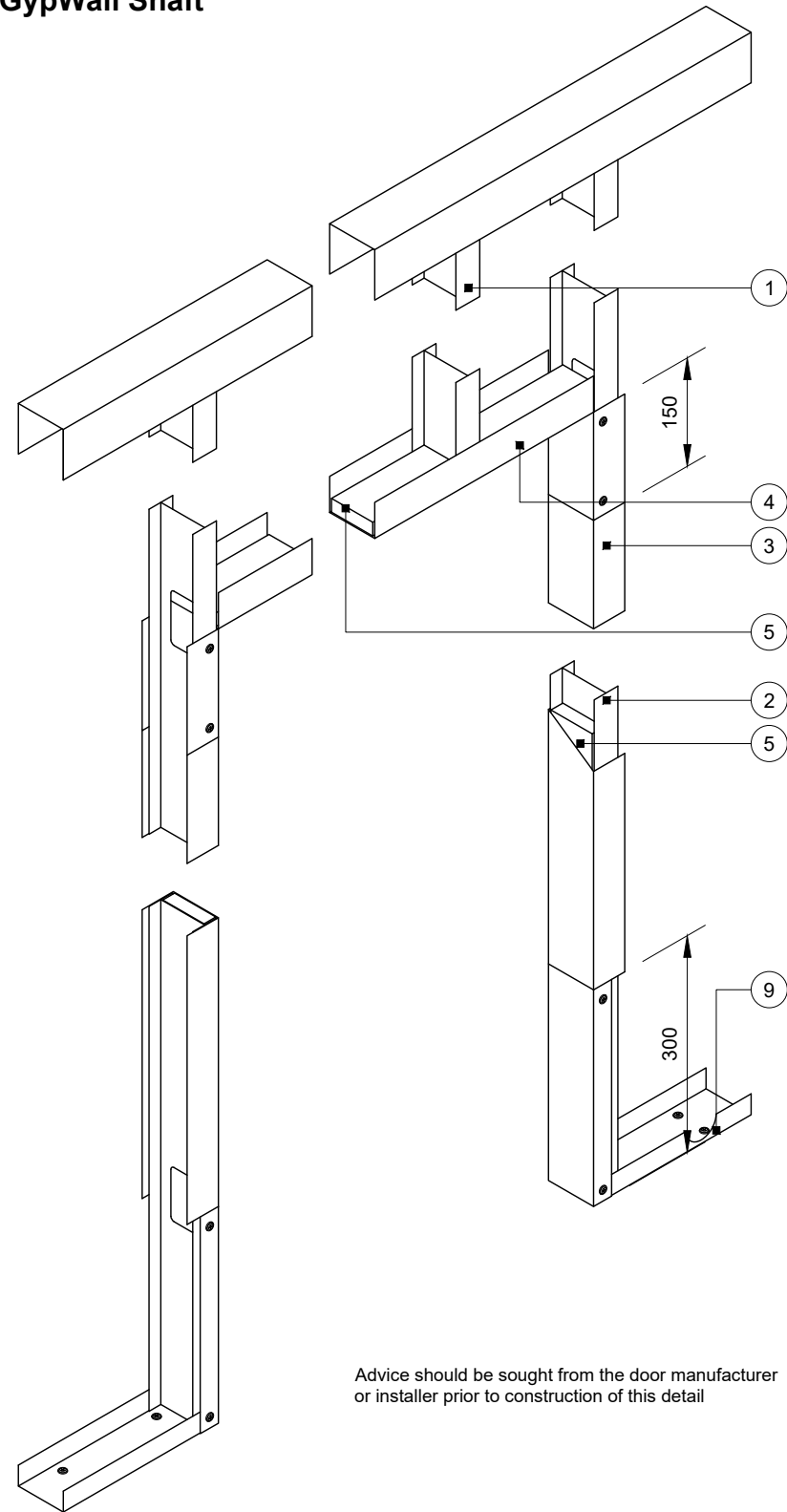

Advice should be sought from the door manufacturer or installer prior to construction of this detail

### Door opening width up to 1200mm

Maximum door weight 60kg following principles of BS 5234: Parts 1 & 2: 1992 - Heavy and Severe Duty subject to specification

### Door and window openings width up to 1200mm

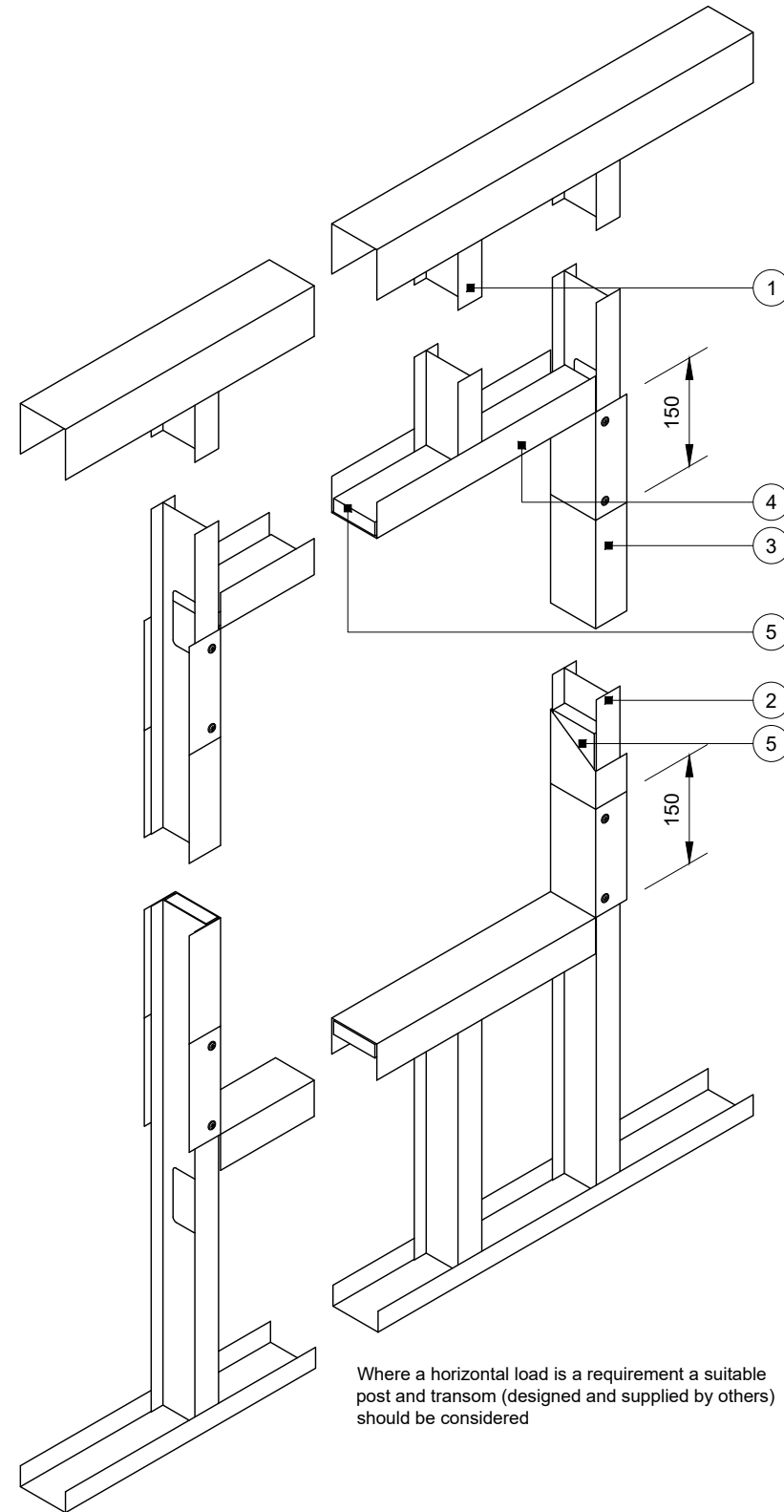

Where a horizontal load is a requirement a suitable post and transom (designed and supplied by others) should be considered

### Opening width up to 1200mm

Partition with one or two layers board

### Important information

Performance characteristics of the British Gypsum system must be maintained. It is important that a suitable fire element/stopping product with appropriate fire resistance substantiation is sought from a third party manufacturer

We would recommend the following substantiation is sought:

- Test should be full scale with suitable size openings
- Test suitable for the required fire resistant/penetrating element and fire duration

This guidance is given with reference to British Gypsum partition systems and how to form openings. With regard to the selection of an appropriate fire resistant/stopping solution it is important that the third party manufacturer is aware of the partition system type that the opening has been created within so that they can confirm that the field of application of any proposed solution is approved for use within the specific partition type being utilised. This is important as fire resistance/stopping tests conducted within a standard flexible construction do not directly cover all end use conditions and may need to be considered by the fire stopping provider on a case by case basis

- 1 Gypframe 'I' studs at specified centres
- 2 Gypframe 'I' stud at jamb
- 3 Gypframe channel sleeved over stud between returned channels at opening head and base
- 4 Gypframe Deep Channel cut and bent to extend 150mm up/down stud and fixed through both flanges with two suitable British Gypsum wafer head screws
- 5 19mm Gyproc CoreBoard or 20mm Glasroc F FireCase packer full opening height and full opening width extended into jamb stud web
- 6 Centre stud required for margin up to 600mm
- 7 Minimum 300mm margin between openings
- 8 No restriction other than system height
- 9 Gypframe channel suitably fixed to floor with two pairs of fixings at 150mm centres (four total) and at 600mm centres (in two lines staggered by 300mm for 94mm and 148mm channels) thereafter. Channel cut and bent to extend 300mm up stud and fixed through both flanges with two suitable British Gypsum wafer head screws. Extra Deep Channel for heights over 8000mm

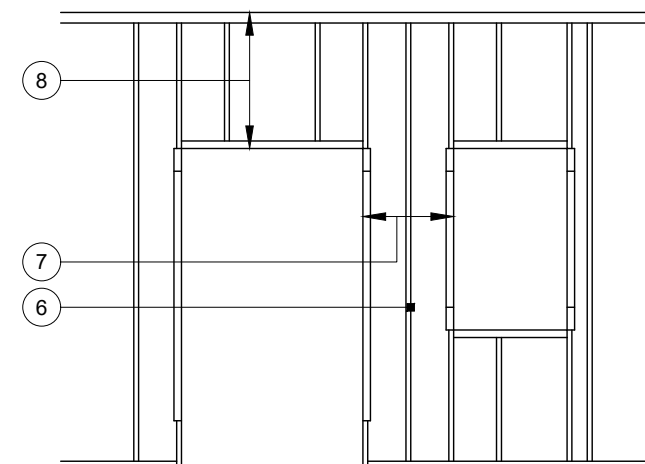

### Partition elevation

Rev. A 20.01.22 Important information added

(MRC)

Title: Construction detail

Scale at A3: 1:10 1:50

Drawn: MRC

Date: December 2021

Approved: MKF JMC

Dwg No.: CN-624-004

Revision: A

Technical Support Team | british-gypsum.com

This drawing is provided to customers free of charge and the details shown are subject to the accuracy of the information provided to British Gypsum at the time the drawing was originally requested. The drawing should therefore be approved by the project design and management authority before use to ensure that it meets with their specific project requirements. It should also be read in conjunction with British Gypsum's current literature available at www.british-gypsum.com. Taping and finishing in accordance with British Gypsum's current recommendations is assumed (with the exception of FireCase system). Please note the drawing may show British Gypsum products fixed by or to products that are non-British Gypsum products/fixings please refer to Specifying Authority for specification details. This drawing is valid at the time of issue, please check with British Gypsum for the latest version. No duty of care is owed to the recipient or any third party and British Gypsum excludes all liability in respect of the details shown save where death or personal injury is caused due to British Gypsum's negligence or for fraud.