

Standard Detail

This drawing provides general guidance where no performance criteria is given and site specific conditions are not taken into account

GypFloor Silent

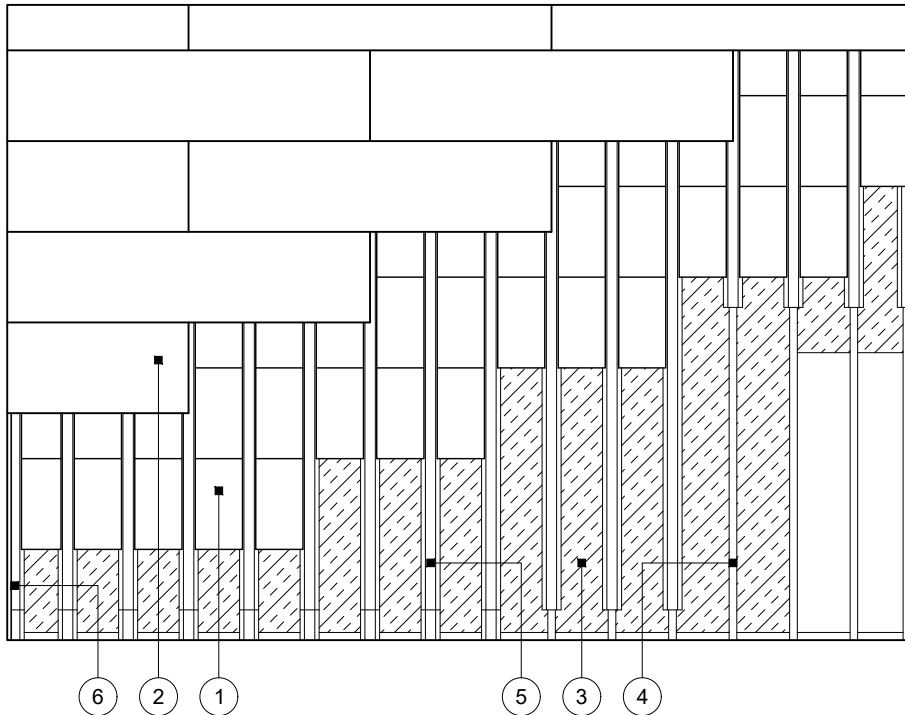

- 1 19mm Gyproc plasterboard cut to fit between floor channels with 3mm gap to vertical flange of floor channel
- 2 Minimum 21mm chipboard or softwood flooring fixed through plasterboard to one side of channel with GypFloor SIF5 Floor Screws
- 3 Isover insulation
- 4 Timber joist
- 5 Gypframe SIF1 Floor Channel located centrally on joist (SIF4 for joist width 64-75mm or two SIF2 for joist width greater than 75mm)
- 6 Gypframe SIF2 Floor Channel in place of SIF1 where joist is within 30mm of wall
- 7 Gypframe RB1 Resilient Bars at max. 450mm centres fixed to each joist with suitable British Gypsum screws
- 8 Short lengths of Gypframe RB1 Resilient Bar fixed to joist with suitable British Gypsum screws
- 9 Two layers Gyproc plasterboard or Glasroc specialist board fixed with suitable British Gypsum screws at 230mm centres in field of board and 150mm centres at board ends

Floor plan

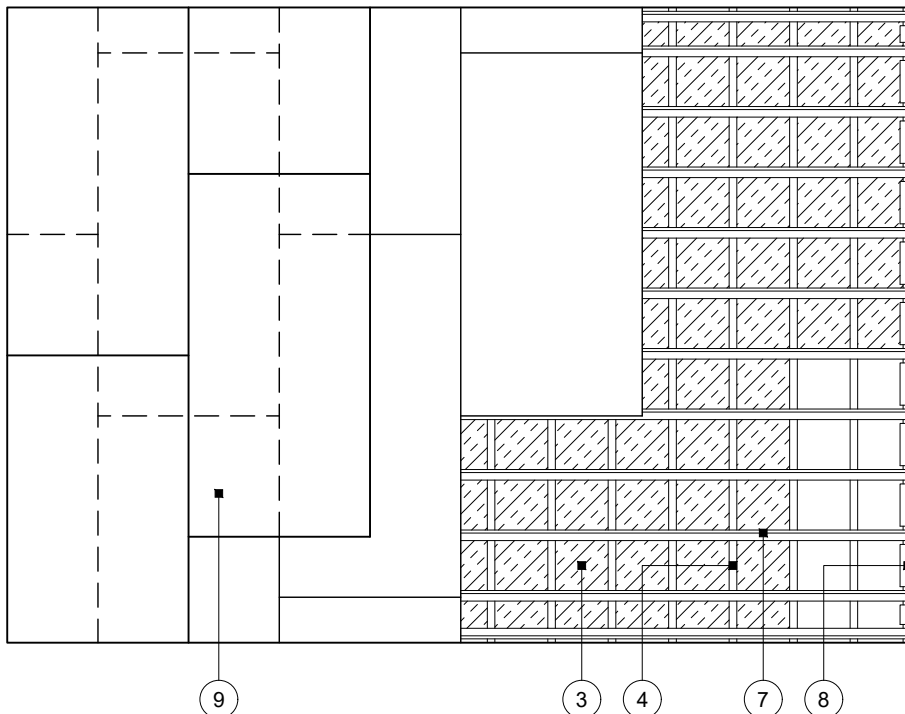

Reflected ceiling plan

Title: GypFloor Silent
Resilient bars and two layers board
Standard details read with project specification

Scale at A4: 1:50
Date: October 2021
Dwg No.: ST-323-RBL2-01

Drawn: MRC
Approved: MBH
Revision:

Technical Support Team | british-gypsum.com

This drawing is provided to customers free of charge and the details shown are subject to the accuracy of the information provided to British Gypsum at the time the drawing was originally requested. The drawing should therefore be approved by the project design and management authority before use to ensure that it meets with their specific project requirements. It should also be read in conjunction with British Gypsum's current literature available at www.british-gypsum.com. Taping and finishing in accordance with British Gypsum's current recommendations is assumed (with the exception of FireCase system). Please note the drawing may show British Gypsum products fixed by or to products that are non-British Gypsum products/fixings please refer to Specifying Authority for specification details. This drawing is valid at the time of issue, please check with British Gypsum for the latest version. No duty of care is owed to the recipient or any third party and British Gypsum excludes all liability in respect of the details shown save where death or personal injury is caused due to British Gypsum's negligence or for fraud.

Standard Detail

This drawing provides general guidance where no performance criteria is given and site specific conditions are not taken into account

GypFloor Silent

- 1 19mm Gyproc plasterboard cut to fit between floor channels with 3mm gap to vertical flange of floor channel
- 2 Minimum 21mm chipboard or softwood flooring fixed through plasterboard to one side of channel with GypFloor SIF5 Floor Screws
- 3 100mm Isover insulation
- 4 Timber joist width less than 64mm
- 5 Gypframe SIF1 Floor Channel located centrally on joist
- 6 Gypframe SIF2 Floor Channel in place of SIF1 where joist is within 30mm of wall
- 7 Gypframe RB1 Resilient Bars at max. 450mm centres fixed to each joist with suitable British Gypsum screws
- 8 Short lengths of Gypframe RB1 Resilient Bar fixed to joist with suitable British Gypsum screws
- 9 2 layers Gyproc plasterboard or Glasroc specialist board fixed with suitable British Gypsum screws at 230mm centres in field of board and 150mm centres at board ends
- 10 Indicative non-loadbearing metal stud partition
- 11 Channel suitably fixed to flooring at 600mm centres (ensure fixings do not penetrate SIF floor channel)
- 12 Timber joist width 64-75mm
- 13 Gypframe SIF4 Floor Channel located centrally on joist
- 14 Timber joist width greater than 75mm
- 15 Two Gypframe SIF2 Floor Channels located on joist (width greater than 75mm) with foam inlay cut away to facilitate overlap (2-3mm clearance gap between channel and side of joist)

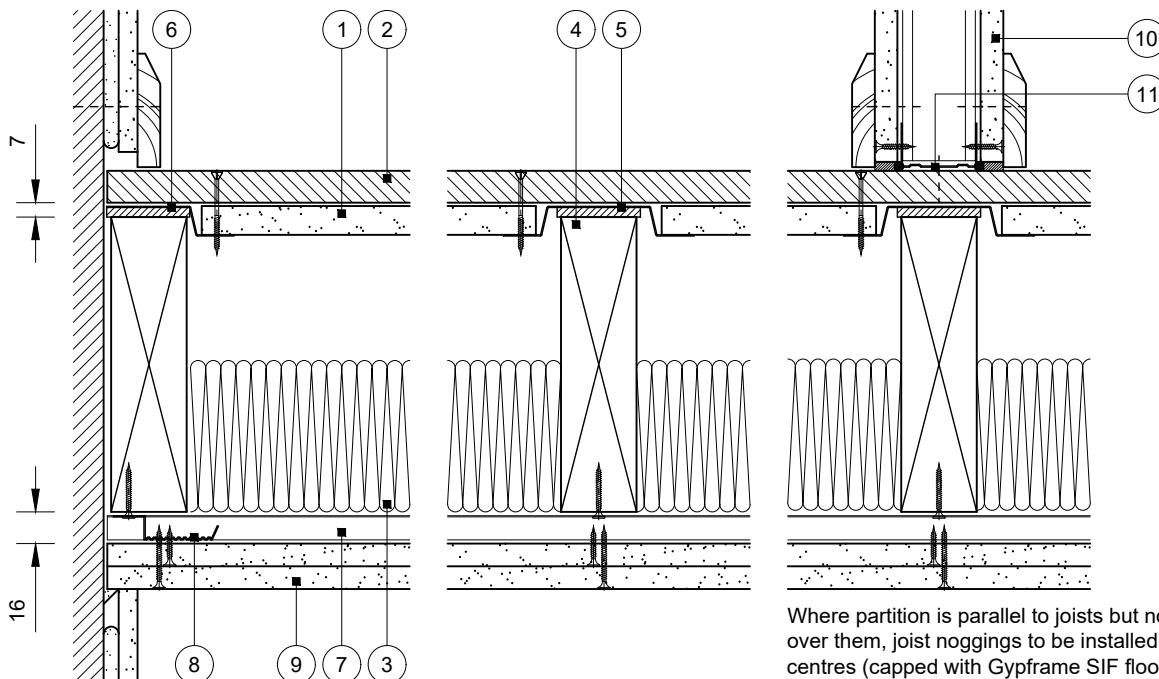

Floor section

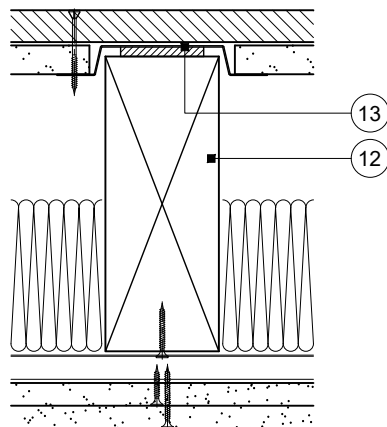

Wider joist

Joist width 64mm to 75mm

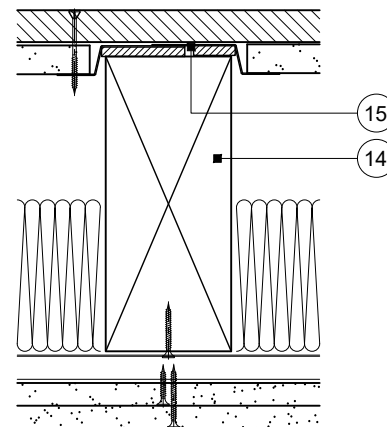

Wider joist

Joist width greater than 75mm

Title: GypFloor Silent
Resilient bar ceiling and two layers board
Standard details read with project specification

Scale at A4: 1:5
Date: October 2021
Dwg No.: ST-323-RBL2-02

Drawn: MRC
Approved: MBH
Revision:

Technical Support Team | british-gypsum.com