

Timber stud

Traditional stud partitions and walls with single or twin frames

The 'traditional' form of plasterboard partition mainly used in residential applications, both in new-build and refurbishment.

Timber stud separating or compartment walls are specified as fire and sound resisting walls in residential units such as flats and apartments to meet the requirements of national Building Regulations.



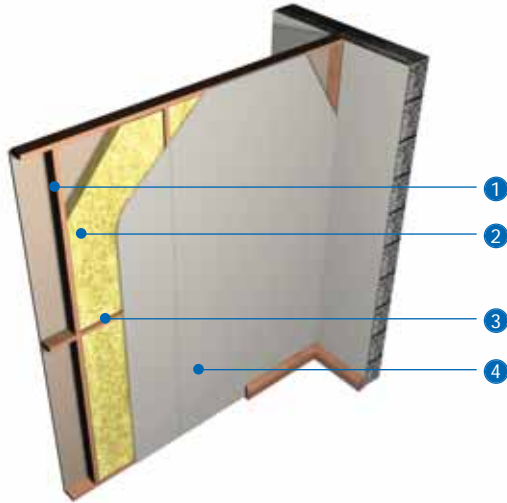

- 1 Timber studs
- 2 Isover insulation
- 3 Horizontal noggings
- 4 Gyproc plasterboard lining

Key facts

- Twin frame and Gypframe RB1 Resilient Bar constructions to meet sound resisting separating wall requirements
- Achieves high levels of fire resistance
- Achieves Part E sound resisting internal partition requirements



Components

Gyproc and Glasroc board products

			Take-off quantities ¹
	Gyproc WallBoard^{2,3}		200m ² per layer
Thickness	12.5, 15mm		
Width	1200mm		
	Gyproc SoundBloc²		200m ² per layer
Thickness	12.5, 15mm		
Width	1200mm		
	Gyproc Plank		200m ² per layer
Thickness	19mm		
Width	600mm		
	Gyproc FireLine³		200m ² per layer
Thickness	12.5 ² , 15mm		
Width	900, 1200mm		
	Glasroc MultiBoard		200m ² per layer
Thickness	6, 10, 12.5mm		
Width	1200mm		

¹ Quantities are for 100m² of straight partition boarded with a double layer of board each side. Quantities are approximate and for guidance only, no allowance has been made for waste, openings, abutments, etc.



Framing

			Take-off quantities ¹
	Timber studs (by others)		as required
Depth	63, 75, 89mm		
Width	as required		
	Gypframe RB1 Resilient Bar		210m per side if specified
For improved acoustic performance.			
Length	3000mm		
	Timber battens (by others)		as required

² Moisture resistant boards are specified in intermittent wet use areas e.g. shower cubicles.

³ Also available in DUPLEX grades where vapour control is required.

Fixing and finishing products		Take-off quantities ¹
	Gyproc Drywall Timber Screws For fixing boards to normal softwoods, super-dried timber and engineered 'I' beams.	1 st layer - 1750 2 nd layer - 2250
	Gyproc Drywall Screws For fixing boards to Gyproframe RB1 Resilient Bars, and Gyproframe RB1 Resilient Bars to softwood timber framing.	1 st layer - 900 per side if required 2 nd layer - 900 per side if required
	Gyproc Sealant Sealing airpaths for optimum sound insulation.	1 cartridge per 35m based on a 6 - 10mm bead
	Gyproc edge beads Protecting and enhancing board edges and corners.	as required

Fixing and finishing products		Take-off quantities ¹
	Thistle Board Finish or Thistle Multi-Finish To provide a plaster skim finish.	10m ² per 25kg bag
	Gyproc jointing materials For seamless jointing.	as required
	Isover APR 1200 For enhanced acoustic performance. 25, 50 and 100mm.	100m ² if specified
	Isover General Purpose Roll For providing acoustic / thermal insulation. 100mm.	100m ² if specified

Construction tips

- To minimise the risk of cracking at plasterboard joints, use seasoned timber with a moisture content not exceeding that recommended in *BS 5268: Part 2*. Even timber complying with the moisture content of *BS 5268* may shrink and twist as it dries, thus nail-popping may still occur
- To minimise the risk of fixing defects occurring, use Gyproc Drywall Timber Screws for fixing into standard softwood, and super-dried timber (approx. 12% moisture content). Fix boards tight to accurately spaced, aligned and levelled framing
- Select the right length of fixing (nominal entry into timber of 25mm, nominal entry into Gypframe RB1 Resilient Bar metal of 10mm)
- Ensure that the dimensions of timber supports are sufficient to allow positive fixing of plasterboards. Bearing surface of existing framing can be increased by fixing timber battens
- Install cavity barriers where specified
- Consider a damp proof membrane on new concrete or screeded floors
- Additional framing will be required to support heavyweight items (e.g. sanitary ware). Ducts and dampers will generally require independent support from the structure

Construction tips (cont'd)

- Consider fixing Gypframe RB1 Resilient Bars to partially isolate linings from timber framing to provide improved acoustic performance
- Use full height boards wherever possible
- Support single layer horizontal board joints with timber nogging
- Install control joints where specified
- Consider skirting fixing – mechanical or using Gyproc Sealant
- For further construction advice, please refer to the UK Timber Frame Association (UKTFA) web site: www.timber-frame.org

Installation

- Determine and mark the wall position and make allowance for openings.
- Fix timber of the required dimensions to the perimeter, abutments and to frame any openings, using appropriate fixings.
- Fix timber studs at appropriate centres.
- Install additional framing as required to support medium to heavy fixtures.
- Install noggings (e.g. mid-height) as required.
- Stagger noggings to allow fixing from back of studs.

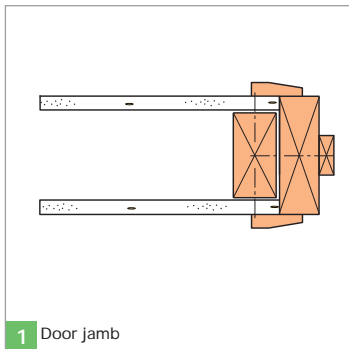

1 Door jamb

- Form door openings by fixing full height studs to each side, together with a timber head piece. Door casings can then be fixed to these timbers.
 - Apply Gyproc Sealant to frame perimeters to provide optimum acoustic performance.
 - Install services (by appropriate trades), normally after one side is boarded.
- NB** Drills / hole saws are required to form service holes in timber studs.

- Fix timber noggings to support recessed switch boxes / socket outlets. Back service outlets with 30mm stone mineral wool (80 kg/m³) to maintain fire integrity, where required. Alternatively Hilti CP617 Putty Pads can be used, contact Hilti for full details, tel: 0800 886100.
- All performance substantiation has to be provided by the fire-stopping manufacturer as is the case for any fire-stopping material.



2

Board fixing - single layer

- Fix boards to timber supports using Gyproc Drywall Timber Screws. The former provide a superior fixing and minimises any risk of fixing defects occurring.
 - Where screws are used, install at 300mm maximum centres (200mm maximum centres at external angles).
- Select the appropriate length of fixing to provide a nominal 25mm penetration into the timber.

- Drive fixings straight and firmly home (not skewed) to leave a shallow depression to facilitate spotting with Gyproc jointing materials.

NB Select the appropriate length of fixing to provide a nominal 25mm penetration into the timber. Refer to **Table 1 – Gyproc plasterboard or Glasroc specialist board fixed to timber supports** in this section, and **Table 2 – Fixing to timber sections** in General site guidance – Board fixing.

- Lightly butt boards, inserting fixings not closer than 10mm from bound edges and 13mm from cut edges.

- Where door openings occur, cut boards around the openings to avoid a joint directly in line with door jambs.

- Stagger board joints relative to the opposite side.

Double layer linings

- Mark the position of studs prior to installing first layer boards.

- After first layer boards have been installed, transfer these dimensions to the lining and mark lines to indicate the position of timber supports. Under layer boards do not require centre fixings.

- Install second layer boards with edges/ends against the centre line of supports with all joints staggered in relation to the first layer. Fix boards to all supports using Gyproc Drywall Timber Screws (preferred).

- Where Gyproc Plank is specified as the base layer, install horizontally and fix to each stud position. Half stagger end joints in alternate courses.

Acoustic detailing

- Install Isover insulation progressively as boarding proceeds.

NB Seal any gaps at the base of linings with Gyproc Sealant (in conjunction with Gyproc Joint Filler) where the partition is required to meet its optimum acoustic performance (see **Junction detail 5**).

Twin frameworks

- Where a twin framework is specified, install the second framework as the first and position so as to achieve the required overall wall thickness.

Installation - Gypframe RB1 Resilient Bar fixing



- If supports are at closer centres trim the board as appropriate.
- Noggings are required to support horizontal joints. Provide support for board ends and edges at the perimeter. Stagger horizontal joints and tape all joints when the board is plastered.
- Fixing - follow the instructions in 'Board fixing - single layer' or double layer as appropriate.

Installation - Gypframe RB1 Resilient Bar fixing

- Where Gypframe RB1 Resilient Bars are required, these are fixed horizontally to the timber studs to one or both sides as specified, at 600mm centres with 36mm Gyproc Drywall Screws.

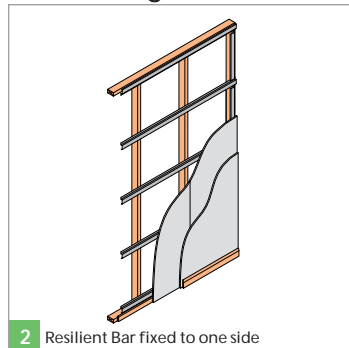

2 Resilient Bar fixed to one side

- The bars are normally fixed with the base flange on the top side, with the exception of the uppermost bar which is fixed base flange down to provide board fixing at the partition head.
- Timber packers (16mm thick) should be used at the base to facilitate skirting fixing.



- Install Gyproframe RB1 Resilient Bar noggings where required to support the lining at corners, openings and abutments.



- Install boards vertically, fixing at 300mm centres along each Gyproframe RB1 Resilient Bar using Gyproc Drywall Screws. Select the fixing to give a minimum 10mm penetration into the metal.
 - Lightly butt boards, inserting fixings not closer than 10mm from bound edges and 13mm from cut edges. Stagger board joints relative to the opposite side.
 - At abutments and openings, insert screw fixings into Gyproframe RB1 Resilient Bar noggings at 300mm centres. At external corners, fixing centres are reduced to 200mm centres.

- For double layer linings mark the position of bars prior to installing first layer board. After first layer boards have been installed, transfer these dimensions to the lining and mark lines to indicate the position of bars.
 - Fix second layer board to Gyproframe RB1 Resilient Bar as for first layer. Stagger board joints.
- NB** Ensure that board fixings into Gyproframe RB1 Resilient Bar clear the timber stud position otherwise acoustic isolation will be impaired.

Table 1 - Gyproc plasterboard or Glasroc specialist board fixed to timber supports

Board type	Thickness mm	Width mm	Recommended stud centres mm
Gyproc WallBoard	12.5	900	450
		1200	600
	15	900	450
		1200	600
Gyproc FireLine	12.5	900	450
		1200	600
	15	900	450
		1200	600
Gyproc Plank	19	600	600
Gyproc SoundBloc	12.5	1200	600
	15	1200	600
Glasroc MultiBoard	10	1200	600
	12.5	1200	600

Junction details

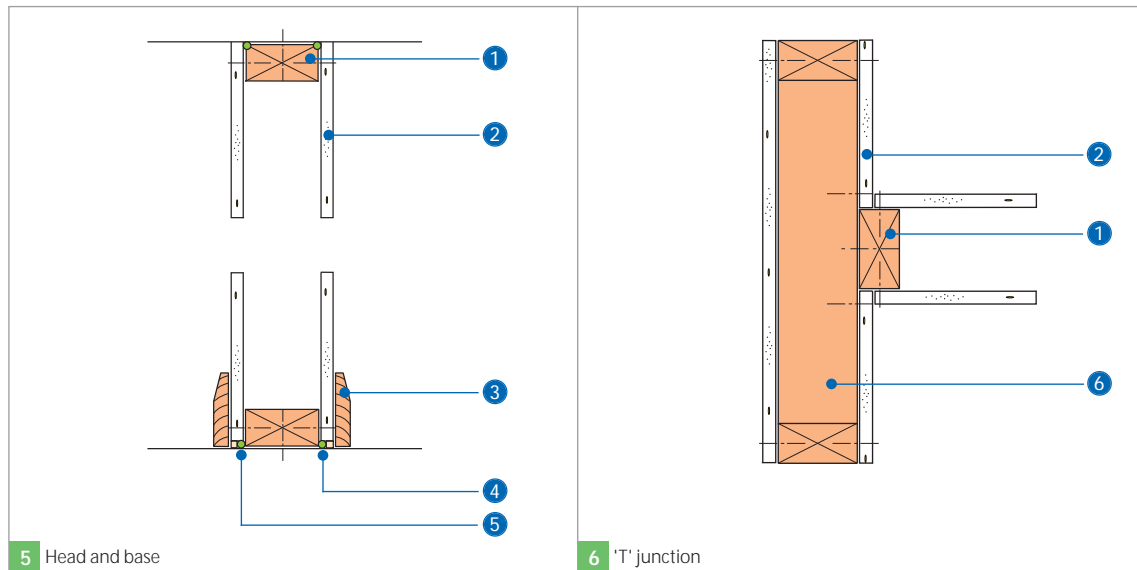

5 Head and base

6 'T' junction

- 1 Timber framing
- 2 Gyproc plasterboard
- 3 Skirting

- 4 Gyproc Sealant
- 5 Bulk filled with Gyproc jointing materials
- 6 Timber ladder frame (ladder members at 600mm max centres)

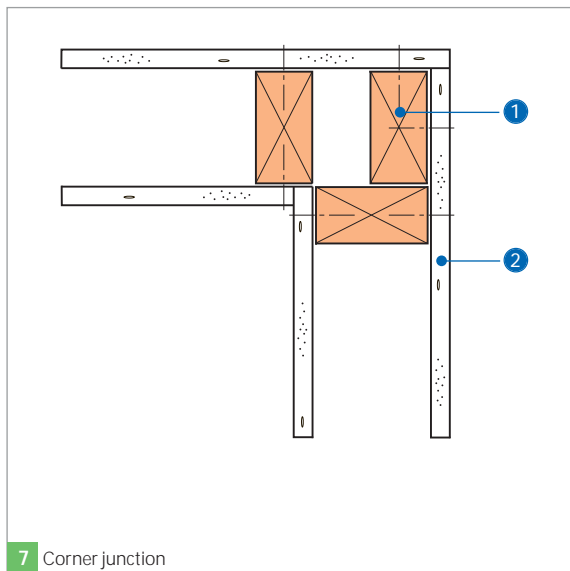

7 Corner junction

- 1 Timber framing
- 2 Gyproc plasterboard