

## Shaft and duct encasement system

ShaftWall provides a lightweight, non-loadbearing fire-resistant structure to protect elements within the service cores of modern fast-track developments. It is also used to protect all forms of shafts and ducts in conventional buildings. The system provides a protective structure which can be incorporated at an early stage of the building before the building envelope is sealed. The system can also be built horizontally to provide a fire-rated membrane. **StairWall** is a derivative of the **ShaftWall** system which is used to protect stairwells.

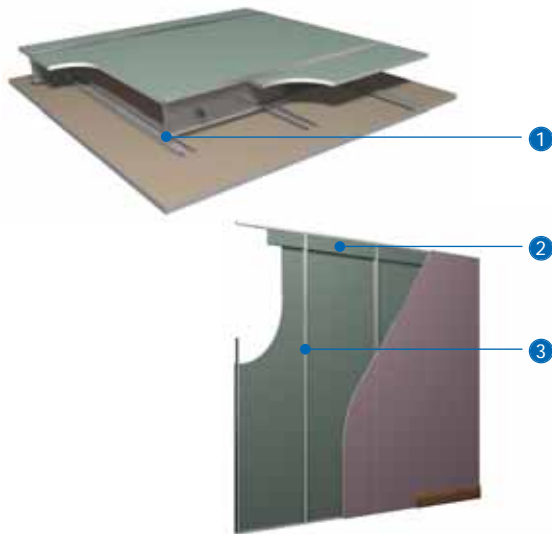





- 1 Gypframe MF5 Ceiling Section
- 2 Gypframe Floor & Ceiling Channel
- 3 Gypframe 'I' Stud, Gypframe Retaining Channel

### Key facts

- Lightweight, fast-track construction
- Provides fire protective shaft enclosures, stairwells and horizontal membranes
- Shaft enclosures built from one side only
- Horizontal membranes built entirely from below
- Can be installed prior to making the building envelope weather-tight
- Minimal wall thickness from 80mm

## Components

### Gyproc and Glasroc board products

			Take-off quantities <sup>1</sup>
	<b>Gyproc FireLine</b>		as required
	Thickness	12.5, 15mm	
	Width	1200mm	
	<b>Gyproc FireLine MR</b>		as required
	Thickness	12.5, 15mm	
	Width	1200mm	
	<b>Gyproc CoreBoard</b>		as required
	Thickness	19mm	
	Width	598mm	
	<b>Gyproc DuraLine</b>		as required
	Thickness	15mm	
	Width	1200mm	

<sup>1</sup> The quantities required for ShaftWall vary significantly depending on the dimensions of the installation and the performance specification of the system. Refer to section 11 - Quantity take-off details.

### Gypframe metal products



		Take-off quantities <sup>1</sup>	
	<b>Gypframe 'I' Studs</b>	as required	
	Widths		60 - 70, 92 - 146mm
	Lengths		3600 - 6000mm
	Codes		60 I 70, 70 I 70 and 92 I 90, 146 TI 90
	<b>Gypframe Starter Channel</b>	as required	
	Widths		60 - 70, 92 - 146mm
	Lengths		3600 - 6000mm
	Codes		60 SC 55, 70 SC 70 and 92 SC 90, 146 TSC 90
	<b>Gypframe 'J' Channel</b>	as required	
	Width		62mm
	Length		3600mm
	Codes	62 JC 70	

Gypframe metal products	Take-off quantities †
 <p><b>Gypframe MF5 Ceiling Section (For horizontal system only)</b> Secondary section below 'I' Studs Length 3600mm</p>	as required
 <p><b>Gypframe Standard Floor &amp; Ceiling Channel</b> Widths 62, 72, 94, 148mm Lengths 3600mm Codes (head) 72 EDC 80, 94 EDC 70, 148 EDC 80 Codes (base) 62 C 50, 72 C 50, 94 C 70, 148 DC 60</p>	as required
 <p><b>Gypframe Retaining Channel</b> G102 (for 60 and 146mm 'I' Studs) G110 (for 70mm 'I' Studs) G105 (for 92mm 'I' Studs) All channels 2400mm</p>	as required
 <p><b>Gypframe Retaining Clips</b> G108 (for 92mm 'I' Studs) G109 (for 146mm 'I' Studs)</p>	as required

Gypframe metal products	Take-off quantities †
 <p><b>Gypframe GA3 Steel Angle</b> Length 3200mm Dimensions 32 x 19 x 0.9mm</p>	as required
 <p><b>Gypframe MF6 Perimeter Channel (For horizontal system only)</b> Perimeter support for MF5's. Length 3600mm</p>	as required
 <p><b>Gypframe 99 FC 50 Fixng Channel</b> Length 2400mm</p>	as required
 <p><b>Gypframe GFT1 Fixing 'T'</b> Length 2400mm</p>	as required
 <p><b>Gypframe GFS1 Fixing Strap</b> Length 2400mm</p>	as required

## Components

### Fixing and finishing products

		Take-off quantities <sup>1</sup>
	<b>Gyproc Drywall Screws</b> For fixing boards to stud framing up to 0.79mm thick.	as required
	<b>Gyproc Jack-Point Screws</b> For fixing boards to stud framing 0.8mm thick or greater and 'I' studs greater than 0.55mm thick.	as required
	<b>Gypframe Wafer Head Jack-Point Screws</b> For metal-to-metal fixing 0.8mm thick or greater and 'I' studs greater than 0.55mm thick.	as required
	<b>Gyproc CoreBoard</b> Dimensions 19 x 68 x 598mm and 19 x 122 x 598mm	as required

<sup>1</sup> The quantities required for ShaftWall vary significantly depending on the dimensions of the insulation and the performance specification of the system. Refer to section 11 - Quantity take-off details.

### Fixing and finishing products

		Take-off quantities <sup>1</sup>
	<b>Gyproc FireStrip</b> For sealing deflection heads.	as required
	<b>Gyproc Sealant</b> Sealing air paths to achieve optimum sound insulation and sealing air shafts.	as required
	<b>Isover APR 1200</b> For enhanced acoustic performance.	as required
	<b>Gyproc jointing materials</b> For a seamless finish.	as required
	<b>Thistle Board Finish or Thistle Multi-Finish</b> To provide a plaster skim finish.	10m <sup>2</sup> per 25kg bag
	<b>Thistle Durafinish</b> To provide improved resistance to accidental damage.	10m <sup>2</sup> per 25kg bag

## Construction tips

- The following points should be considered in addition to the construction tips for **GypWall classic**
- The estimated construction time is 1.5m<sup>2</sup> - 2m<sup>2</sup> / man hour (single layer wall with deflection head) or 1m<sup>2</sup> - 1.5m<sup>2</sup> / man hour (double layer wall with deflection head) ready for finishing
- If the building envelope is left unsealed while **ShaftWall** is under construction, Gyproc FireLine **MR** should be used for the lining
- The use of pressure conditions in various types of shaft / duct requires that the boards should be sealed into the framing members using Gyproc Sealant in addition to the normal sealing of the framing to adjoining structures. It is essential that these areas are identified at a very early stage of the contract and that other trades are instructed to recognise the need for application of sealant and its replacement if subsequently damaged or removed
- If possible, plan the **ShaftWall** layout off the line of structural steelwork. This avoids special detailing such as fire protected **Z** bars
- The floor track must have continuous support from the structure

## Construction tips (cont'd)

- In high usage areas the face lining of Gyproc FireLine can be substituted by Gyproc DuraLine to provide a high impact resistant lining. Fire resistance will not be compromised provided that an equivalent minimum thickness of board is used
- If required for aesthetic reasons, it is permitted to fix an additional layer of 12.5mm Gyproc WallBoard to the exposed stud flanges on the shaft side to provide a smooth, seamless surface

## Installation



The following procedure relates to a 60mm framework, with a 15mm deflection head. Specific references are made where the procedure for 70mm, 92mm or 146mm frameworks differs from this. The wall is installed from the room side in one direction.



- Mark the position of the wall.
- Fix floor channel at 600mm maximum centres.
- Fix head channel aligned and plumb with the floor channel at 300mm maximum centres (unless fixing to Z sections which are set at 600mm centres, when two fixings to each Z section must be used).
- Position the deep flange of the Gyprframe 'J' Channel to the shaft or stairwell side.



- Apply continuous Gyproc FireStrip to the centre line of the head channel prior to fixing to maintain fire performance.
- NB** For 92mm and 146mm framing, fix head and floor channel using two rows of staggered fixings, spaced at 600mm in each row.



- Cut the Starter Channel 15mm short of the measured distance between floor and head channels in order to accommodate the designed deflection.



5

- Insert into position, leaving a 15mm space at the head, and fix to the vertical abutments at 600mm maximum centres.
- For 146mm Tabbed Starter Channel and stud, the tabs must be located closest to the shaft side.



6

- Cut Gypframe 'I' Studs and Gyproc CoreBoard 15mm short of the measured distance between floor and head channels.
- Insert Gyproc CoreBoard between the channels and push tightly into the vertical Starter Channel (use the Gypframe 'I' Stud to temporarily and loosely support the opposite edge of the Gyproc CoreBoard).



7

- Fix Gypframe Starter Channels to steel door frames at 300mm maximum centres.
- Carry out adjustments of alignment to the vertical with the first Gyproc CoreBoard (all studs must remain vertical throughout the fixing operation, and all cut ends of Gyproc CoreBoard must be square cut for use at the base and horizontal joints).



- Fix two 19mm x 122mm Gyproc CoreBoard fire-stops (cut on site) between the webs and behind the vertical flanges of the studs and into the head channel (see **Junction details – deflection heads**).

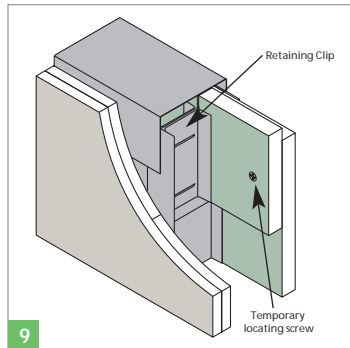

- For 92mm and 146mm frameworks two head details are available for each. The simplified detail incorporating a Gypframe Retaining Clip accommodates deflection in respect of initial building settlement. Fix as follows:
  - Friction fit a Retaining Clip into the top flanges of each Gypframe 'I' Stud so as to retain a single Gyproc CoreBoard fire-stop within the head channel. Use the Gypframe G108 component with 92mm framing and Gypframe G109 with 146mm framing.
- The alternative head detail can accommodate deflection due to live loads. This adopts a dropped soffit and uses two Gyproc CoreBoard fire-stops (cut on site) fixed horizontally to the web of the head channel. Use 19mm x 50mm with a 70mm framework, use 19mm x 68mm fire-stops with a 92mm framework and 19mm x 122mm fire-stops with a 146mm framework (see **Junction details – deflection heads**).



10

- Position Gypframe G102 Retaining Channel in the Starter Channel (use Gypframe G110 Retaining Channel in the case of a 70mm framework and Gypframe G105 Retaining Channel in the case of a 92mm framework).

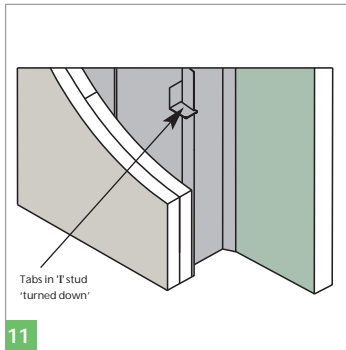

11

- Ensure that the Gypframe G102 Retaining Channel is securely located in the tabs when using 146mm framing.
- Push the Gypframe 'I' Stud into its permanent position to secure the first section of core boards.
- To simplify the installation of the final Gyproc CoreBoard when working between fixed points, cut boards to the required width, (minimum 300mm), less 10mm fitting tolerance. Insert the boards by twisting the flange of the last stud.

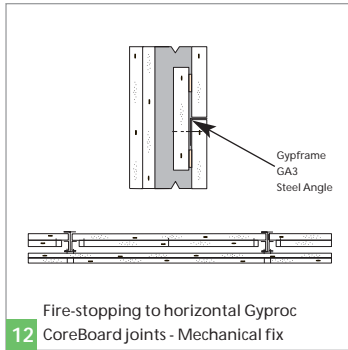

- Fire-stop horizontal joints between Gyproc CoreBoard using a 19mm x 122mm Gyproc CoreBoard fire-stop (cut on site). Fix the fire-stop to Gypframe GA3 Steel Angle using three Gyproc Jack-Point Screws, and beads of sealant top and bottom.



- NB** Before lining board fixing commences, inspect the Gyproc CoreBoard to ensure that all components including fire-stops are correctly located. Apply Gyproc Sealant in the angle formed by the perimeter framing structure.



### Board fixing

- Screw-fix tapered edge Gyproc FireLine base layer boards at 300mm centres to all framing members.
- Screw-fix outer layer boards to all framing members at 300mm centres (200mm at external angles) and stagger board joints between layers.



- Where there is a horizontal joint in the lining boards, stagger end joints by 600mm minimum between layers.

- Cut lining boards 15mm short to allow for the deflection. Do not fix into the flange of the head channel (see **Junction details – deflection heads**)



- Install Gypframe GFT1 Fixing 'T' to support the end joints of single layer boards. Fix Gypframe GFS1 Fixing Strap instead in double layer boarding between board layers.
- Insert screws at 300mm centres.



### Airshafts

Where **ShaftWall** is used to enclose air pressure ducts, Gyproc Sealant is used to seal potential airpaths (see **Junction details – Sealing air shafts and service ducts**).

- Apply sealant to the inside face of the rear flanges of Gypframe 'I' Studs, head channel, floor channel and Gypframe Starter Channels.



- Seal Gyproc CoreBoard fire-stops, which are located over the horizontal joints in Gyproc CoreBoard, by applying beads of Gyproc Sealant prior to fixing.
- Seal the first layer lining boards to the framework, applying Gyproc Sealant only to the face flange of the perimeter channels.

### Services

- Penetrations of **ShaftWall** by services, ducts, control joints and general openings will require careful detailing. This is to ensure that the penetration does not impair the fire resistance of the wall or act as a mechanism of fire spread. Specific construction details should be determined by the designer.

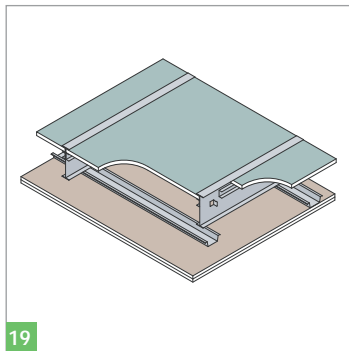

19

### Horizontal ShaftWall

Horizontal **ShaftWall** is installed generally as for vertical installation with the following exceptions.

- Use 'JC' or 'EDC' Channels to receive horizontal studs.
- Fix studs into channels using Gyproc Wafer Head Jack-Point Screws, into both legs of the channel.
- Plasterboard fire-stops are not required.

- Gypframe MF6 Perimeter Channel required at perimeter, immediately below the **ShaftWall** channels, fixed at 600mm centres.
- Gypframe MF5 Ceiling Section fixed at maximum 450mm centres to the underside of the Gypframe 'I' Studs with two Gyproc Wafer Head Jack-Point Screws.
- Gypframe MF5's Ceiling Section should run at right angles to the Gypframe 'I' Studs.

- Ceiling linings to be installed generally in line with **CasoLine MF** system (centres not exceeding 230mm in field of board and 150mm at board ends).

## Junction details - general

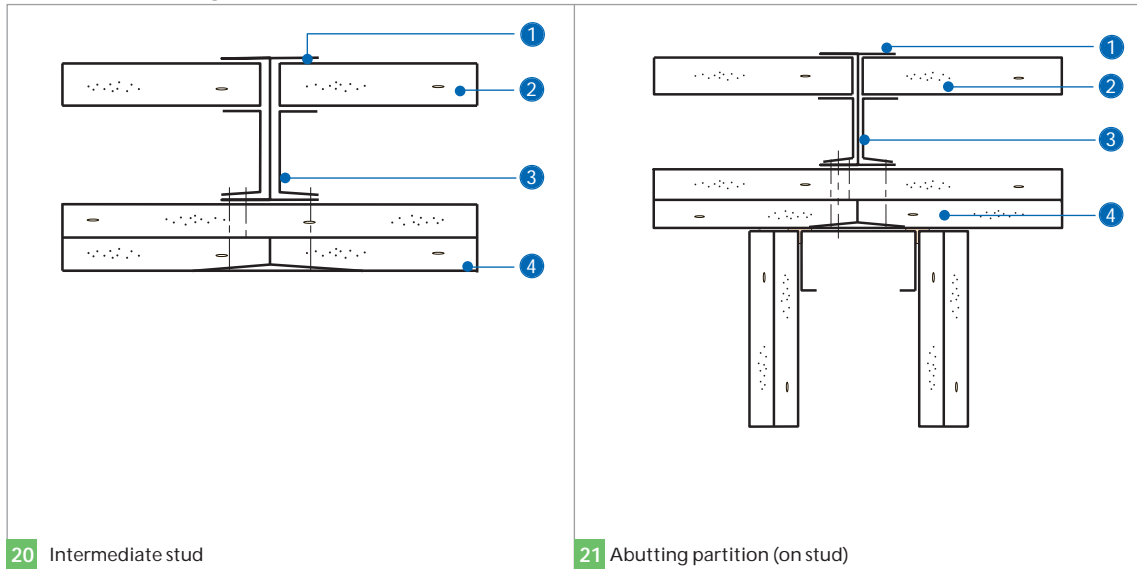

20 Intermediate stud

21 Abutting partition (on stud)

- 1 Gypframe 'I' Stud
- 2 Gyproc CoreBoard
- 3 Gypframe Retaining Channel

- 4 Gyproc FireLine / Gyproc DuraLine

## Junction details - deflection heads

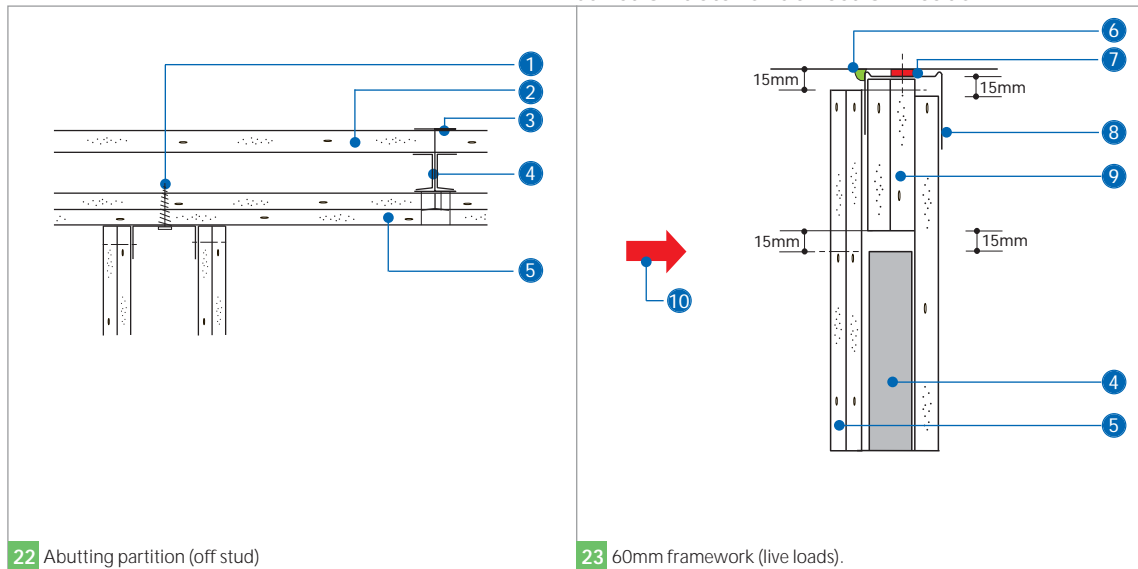

1 Metal self-drive fixing

2 Gyproc CoreBoard

3 Gypframe 'I' Stud

4 Gypframe Retaining Channel

5 Gyproc FireLine / Gyproc DuraLine linings

6 Gyproc Sealant

7 Gyproc FireStrip

8 Gypframe 'J' Channel

9 Gyproc CoreBoard fire-stop –  
122mm (cut on site)

10  Upper line of board fixing into  
Gypframe 'I' Stud

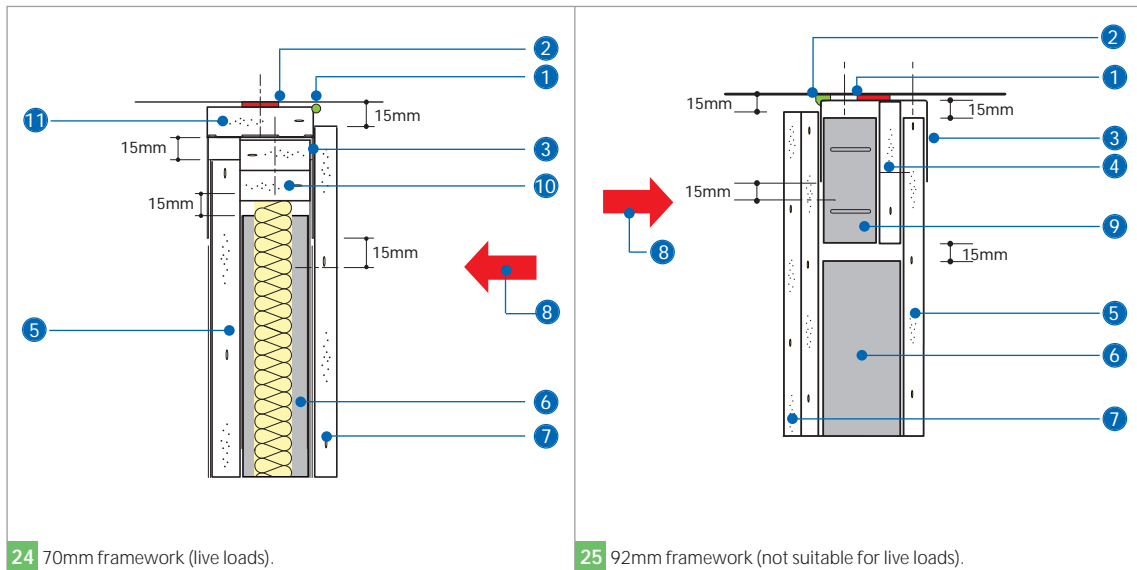

- 1 Gyproc Sealant
- 2 Gyproc Firestrip
- 3 Gypframe Extra Deep Flange Floor & Ceiling Channel
- 4 Gyproc CoreBoard fire-stop 122mm

- 5 Gyproc CoreBoard deep (cut on site)
- 6 Gypframe Retaining Channel
- 7 Gyproc FireLine / Gyproc DuraLine linings
- 8 Upper line of board fixing into

- 9 Gypframe G108 Retaining Clip
- 10 Gyproc CoreBoard fire-stop nominally 50mm wide (cut on site)
- 11 Gyproc CoreBoard as dropped soffit

## Junction details - deflection heads (cont'd)

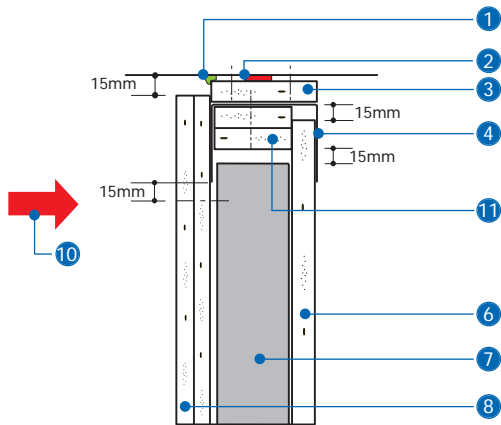

26 92mm framework (live loads).

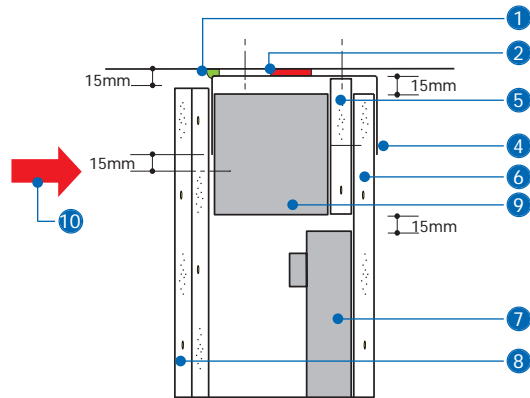

27 146mm framework (not suitable for live loads).

- 1 Gyproc Sealant
- 2 Gyproc FireStrip
- 3 Gyproc CoreBoard as dropped soffit
- 4 Gypframe Extra Deep Flange Floor & Ceiling Channel

- 5 Gyproc CoreBoard fire-stop – 122mm deep (cut on site)
- 6 Gyproc Core Board
- 7 Gypframe Retaining Channel
- 8 Gyproc FireLine / Gyproc DuraLine linings

- 9 Gypframe G109 Retaining Clip
- 10  Upper line of board fixing into Gypframe 'I' Stud
- 11 Gyproc CoreBoard fire-stops nominally 68mm wide (cut on site)

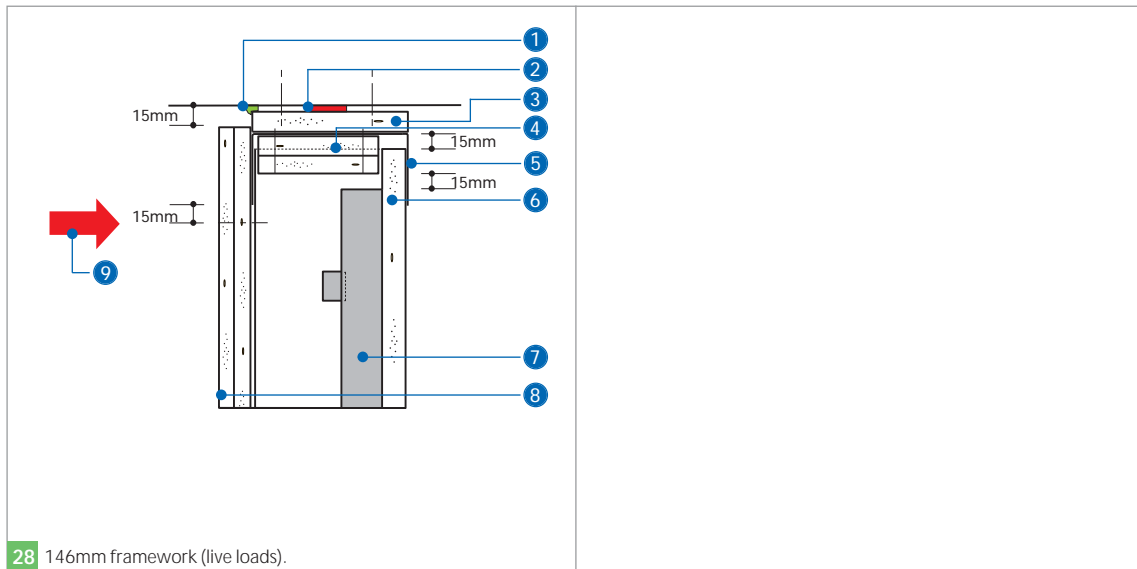

28 146mm framework (live loads).

- |  |  |   |
|--|--|---|
| 1 Gyproc Sealant                                   | 5 Gyproframe Extra Deep Flange Floor & Ceiling Channel | 8 Gyproc FireLine / Gyproc DuraLine linings   |
| 2 Gyproc FireStrip                                 | 6 Gyproc CoreBoard                                     | 9  Upper line of board fixing into Gyproframe 'I' Stud |
| 3 Gyproc CoreBoard as dropped soffit               | 7 Gyproframe Retaining Channel                         |   |
| 4 Gyproc CoreBoard fire-stop – 122mm (cut on site) |  |   |

## Junction details - Gyproc Proflex Access Panel

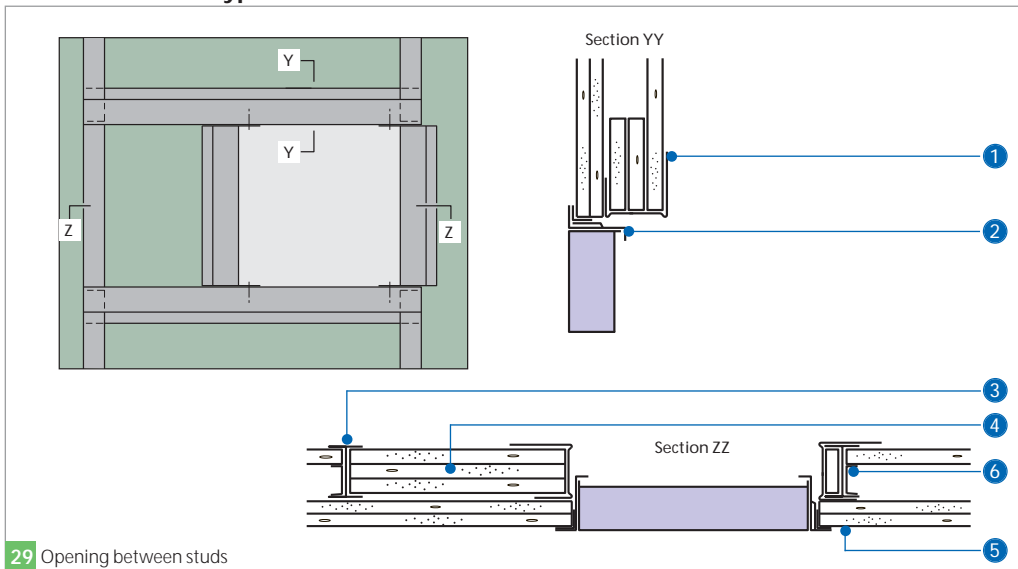

- 1 Gyproframe 'J' Channel (to frame the opening)
- 2 Gyproc Proflex Access Panel
- 3 Gyproframe 'I' Studs
- 4 Gyproc CoreBoard
- 5 Gyproc FireLine / Gyproc DuraLine lining
- 6 Gyproframe Retaining Channel

## Junction details - doors

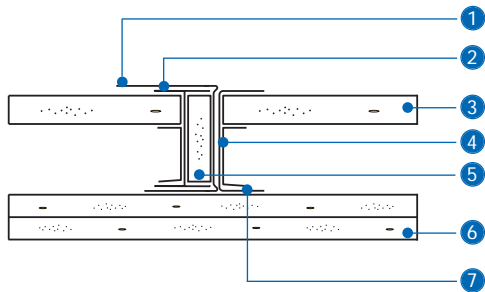

30 Access door - spandrel panel detail

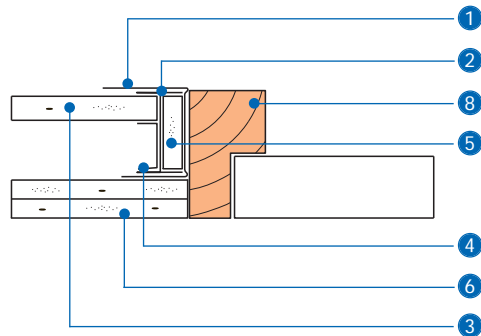

31 Access door jamb detail

- 1 Gyprframe 'J' Channel
- 2 Gyprframe 'I' Stud
- 3 Gyproc CoreBoard

- 4 Gyprframe Retaining Channel
- 5 Gyproc CoreBoard packer (cut on site)
- 6 Gyproc FireLine / Gyproc DuraLine linings

- 7 Gyprframe Starter Channel
- 8 Door frame

## Junction details - sealing air shafts &amp; service ducts

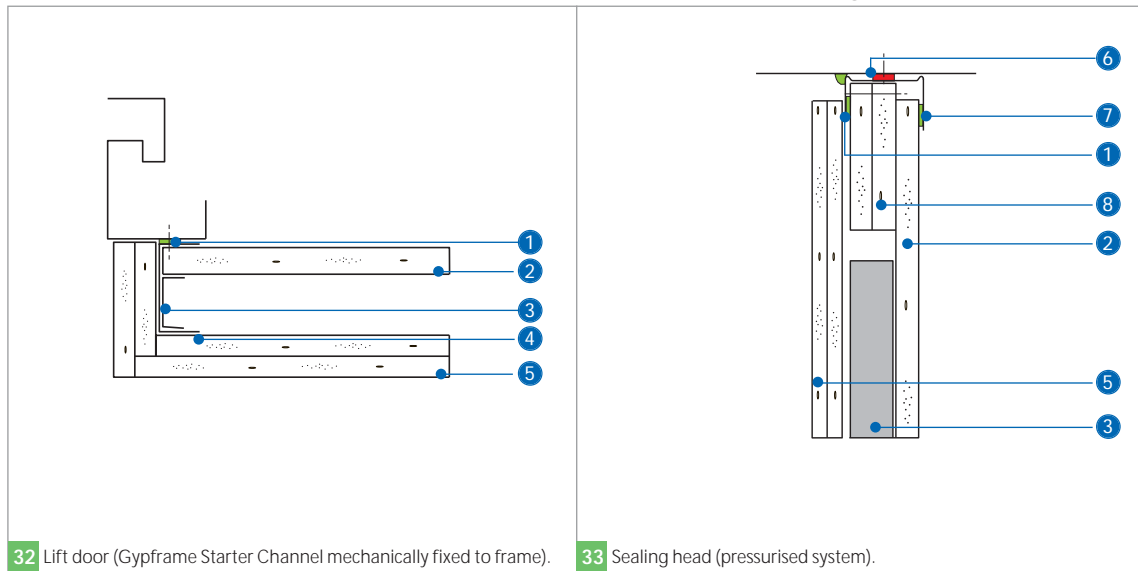

1 Gyproc Sealant

2 Gyproc CoreBoard

3 Gypframe Retaining Channel

4 Gypframe Starter Channel

5 Gyproc FireLine / Gyproc DuraLine linings

6 Gyproc FireStrip

7 Gypframe 'J' Channel

8 Gyproc CoreBoard fire-stop (cut on site)

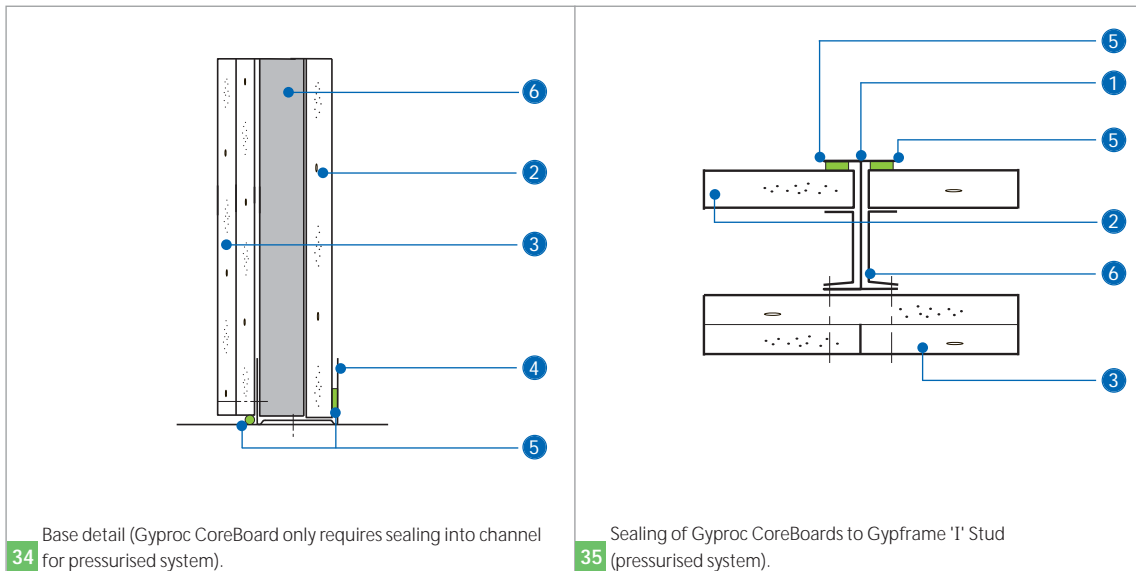

- 1 Gypframe 'I' Stud
- 2 Gyproc CoreBoard
- 3 Gyproc FireLine / Gyproc DuraLine linings
- 4 Gypframe Floor & Ceiling Channel
- 5 Gyproc Sealant
- 6 Gypframe Retaining Channel

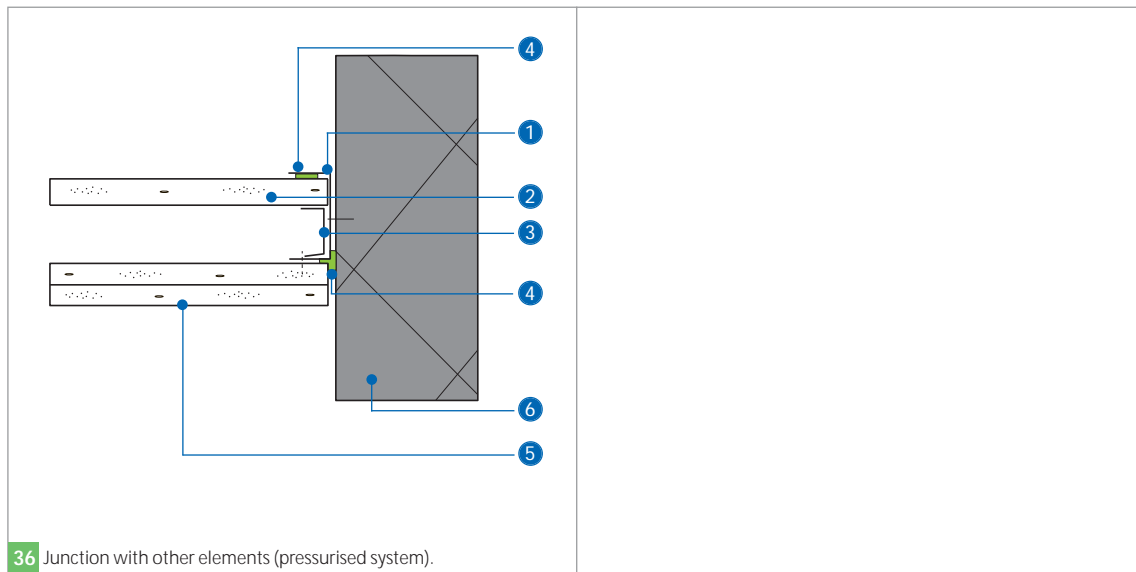

36 Junction with other elements (pressurised system).

- |                             |   |
|-----------------------------|---|
| 1 Gyprame Starter Channel   | 4 Gyproc Sealant                            |
| 2 Gyproc CoreBoard          | 5 Gyproc FireLine / Gyproc DuraLine linings |
| 3 Gyprame Retaining Channel | 6 Structure                                 |

