

## Floating floor treatment for separating floors

GypFloor SB, incorporating Gypframe Steel Battens, is a unique floating floor system for use within residential separating floors. The system offers significant improvements in airborne and impact sound insulation on timber and concrete constructions to meet the requirements of national Building Regulations Approved Document E.

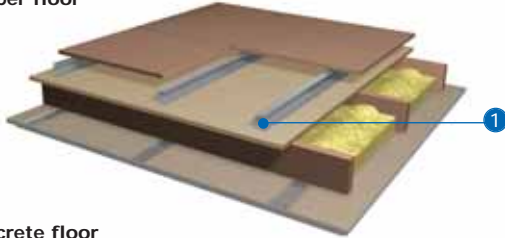

### Timber floor



### Concrete floor

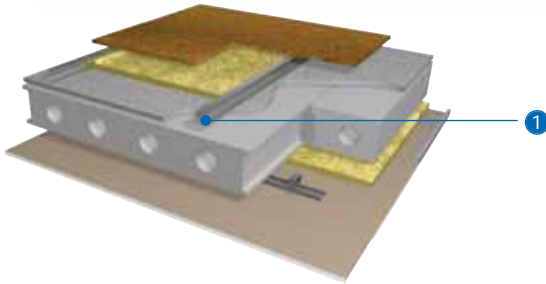



1 Gypframe 70 SB 65 Steel Batten or Gypframe 50 SB 65 Steel Batten. Gypframe SB4 Levelling Cradle and Gypframe SB5 Levelling Packer

### Key facts

- GypFloor **sb** is incorporated within a range of British Gypsum separating floor systems approved by the SpecSure® system lifetime system warranty
- The system incorporates lightweight engineered Gypframe UltraSTEEL® components
- Gypframe cradles and packers provide option for levelling uneven sub-structures
- 50mm and 70mm battens provide two options for service requirements
- Galvanised Gypframe Steel Battens can be stored externally
- GypFloor **sb** offers a walking surface of superior stability and a solid platform upon which lightweight non-loadbearing partitions and ceramic tiling can be installed

## Components

### Gyproc board products

			Take-off quantities <sup>1</sup>
	<b>Gyproc SoundBloc</b>		100m <sup>2</sup> per layer
	Thickness	12.5, 15mm	
	Width	1200mm	
	<b>Gyproc FireLine<sup>2</sup></b>		100m <sup>2</sup> per layer
	Thickness	12.5mm	
	Width	1200mm	
	<b>Gyproc Plank</b>		100m <sup>2</sup> for floor if specified 100m <sup>2</sup> for ceiling if specified
	Thickness	19mm	
	Width	600mm	

### Gypframe metal products

			Take-off quantities <sup>1</sup>
	<b>Gypframe 50 SB 65 Steel Batten</b>		295m
	For use with shallow batten system		
	Length	1800mm	
	Depth	50mm	
	<b>Gypframe 70 SB 65 Steel Batten</b>		295m
	For use with deep batten system		
	Length	1800mm	
	Depth	70mm	
	<b>Gypframe SB3 Flanking Strip</b>		40m
	To eliminate flanking sound transmission		
	Length	10m roll	
	Width	150mm	
	<b>Gypframe SB4 Levelling Cradle</b>		540
	For use on uneven masonry sub structure		
	<b>Gypframe SB5 Levelling Packer</b>		540
	For use in SB4 levelling cradles on uneven masonry sub-structure.		



<sup>1</sup> Quantities are for 100m<sup>2</sup> of regular shaped rectangular floor with a chipboard walking surface and a double layer ceiling installation with Gypframe RB1 Resilient Bar component at 450mm centres. Quantities are approximate and for guidance only, no allowance has been made for waste.

<sup>2</sup> Also available in DUPLEX grades where vapour control is required.

<sup>3</sup> GypLyner UNIVERSAL ceiling components see 7 - GypLyner UNIVERSAL. For CasoLine MF ceiling components see 7 - CasoLine MF.

British Gypsum ceiling systems <sup>3</sup>		Take-off quantities <sup>7</sup>
	<b>Gypframe RB1 Resilient Bar</b> Length 3000mm	250m if specified

#### Fixing and finishing products

	<b>Gypframe SIF5 Floor Screws</b> For fixing floorboards through Gyproc Plank into the Gypframe steel battens.	1250
	<b>Glasroc FireCase Screws</b> For fixing floorboards through Gyproc Plank into the Gypframe steel battens.	1250
	<b>Gyproc Drywall Screws</b> For fixing ceiling boards to Gypframe Resilient Bars.	1800

#### Fixing and finishing products

Fixing and finishing products		Take-off quantities <sup>7</sup>
	<b>Gyproc Sealant</b> Sealing air paths for optimum sound insulation.	1 cartridge per 35m based on a 6 - 10mm bead
	<b>Gyproc jointing materials</b> For a seamless finish.	as required
	<b>Thistle Board Finish or Thistle Multi-Finish</b> To provide a plaster skim finish.	10m <sup>2</sup> per 25kg bag
	<b>Isover General Purpose Roll</b> For providing acoustic / thermal insulation.	100m <sup>2</sup>
	<b>Isover APR 1200</b> For enhanced acoustic performance. 25mm and 50mm.	100m <sup>2</sup>

## Construction tips

- Allow a 50mm gap between the room perimeter and Gypframe Steel Battens
- Perpendicular battens are laid with a 25mm gap between sections
- Adjoining Gypframe Steel Battens are lightly abutted - no complicated fixing or nesting techniques required
- Gypframe Steel Battens can be fixed to the sub deck to aid installation, where required, and making them compatible with off site manufacturing of floor cassettes
- Fix Gypframe SB3 Flanking Strip to minimise sound transmission from walking surfaces into separating walls
- When laying battens around services, stop one batten 25mm short of the pipes or cables, then start the next batten 25mm after. Cutting holes in battens for services should be avoided

## Installation



- Before starting work, ensure floor area is swept clear of loose material and debris. Additionally, to allow adhesion of flanking strip, ensure surrounding walls are free from dust and loose material.



2

- Position Gypframe SB3 Flanking Strip around the room perimeter against the lower part of the wall. Any excess strip can be cut away once the floor is laid.

**NB** Staple fixing Gypframe SB3 Flanking Strip to plasterboard lining is an easy method.

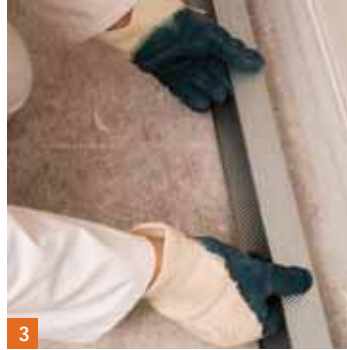

3

- Lay Gypframe Steel Battens around the room perimeter leaving a 50mm gap between the wall and the batten.



4

- Cut Gypframe Steel Battens with tin snips or a chopsaw.



- The design loadings for self contained dwelling units, as defined in *BS 6399: Part 1*, are: intensity of distributed load 1.5kN/m<sup>2</sup> concentrated load 1.4kN
- For these normal (domestic) loading requirements, position Gypframe Steel Battens at 400mm centres.

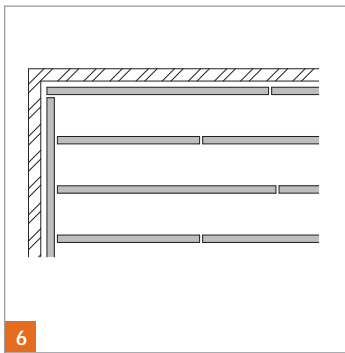

- A 25mm gap should be left between perpendicular sections. The battens should be staggered by a minimum of 600mm to avoid the occurrence of more than one joint under any one piece of flooring.



- When using the system on uneven sub-floors, Gypframe SB4 Levelling Cradles can be positioned under the sections.



- Gypframe levelling cradles should be positioned at 600mm centres when installing 50mm battens. For 70mm battens position cradles at 450mm centres.
- Gypframe SB5 Levelling Packers can be used inside the cradle, as required.

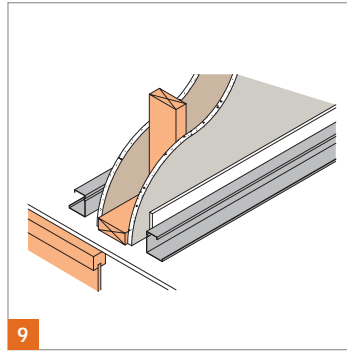

- Loadbearing partitions and separating walls should be erected directly onto the sub-floor. Non-loadbearing partitions, such as the **GypWall** range, can be erected on top of the **GypFloor SB** system. Provision should be made in the layout to allow one or two (depending on partition width) Gypframe Steel Battens beneath the partition to give support and a fixing ground.

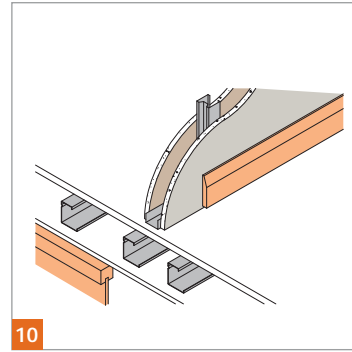

- To minimise the effect of any camber on concrete sub-floors, partitions can be mounted into the sub-floor, thus minimising the effect of the camber by dividing the floor area into individual rooms.

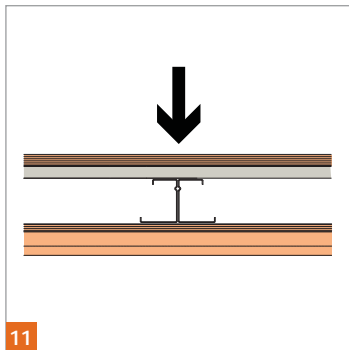

11

- Battens can be installed back to back to provide additional support as necessary



12

- Where specified, Isover glass mineral wool is laid within the cavity between the battens.



13

- Where specified, Gyproc Plank is laid perpendicular to the battens and staggered with a minimum 10mm expansion gap left around the perimeter. The ends of the Gyproc Plank should be supported by a Gypframe Steel Batten. Gyproc Plank is fitted by lightly butting edges together. No screw-fixings are required, however, screws can be used to aid installation by securing boards in place.



- Tongue and groove chipboard is laid perpendicular to the Gyproc Plank, with a minimum stagger of 150mm. A minimum 10mm expansion gap is left around the perimeter. Apply glue (as recommended by the chipboard manufacturer) to the tongued joints before butting together. Excess glue should be removed from the face of the chipboard before it dries by using a damp cloth.



- Gypframe SIF5 Floor Screws are suitable for fixing the walking surface to the battens.

**NB** All fixings into **GypFloor sb** sections should protrude through the top of the section a minimum 10mm, but not protrude through the whole section.



- To fix skirting boards, first fold protruding flanking strip onto the face of the flooring. The skirting is then fixed as normal, so that it rests on the flanking strip. Any excess flanking strip can be trimmed flush to the face of the skirting.



17

### Services

- Services are incorporated into the GypFloor sb system by allowing a gap in the sections. The gap should be 25mm from either side of the service. If access is required, a floor hatch can be formed from the flooring material (i.e. chipboard, or chipboard and Gyproc Plank).

- Gyproframe Steel Battens should be positioned around the perimeter of the hatch to support the hatch and the main floor. As a guide, maximum hatch size should not be greater than the batten spacing (400 X 400mm or 600 x 600mm maximum).

